

SERVICE INSTRUCTION

DGC - Hose Unit

2" - Design 2.0



VERSION: 251120

MannTek

DGC – HOSE UNIT – 2” – DESIGN 2.0

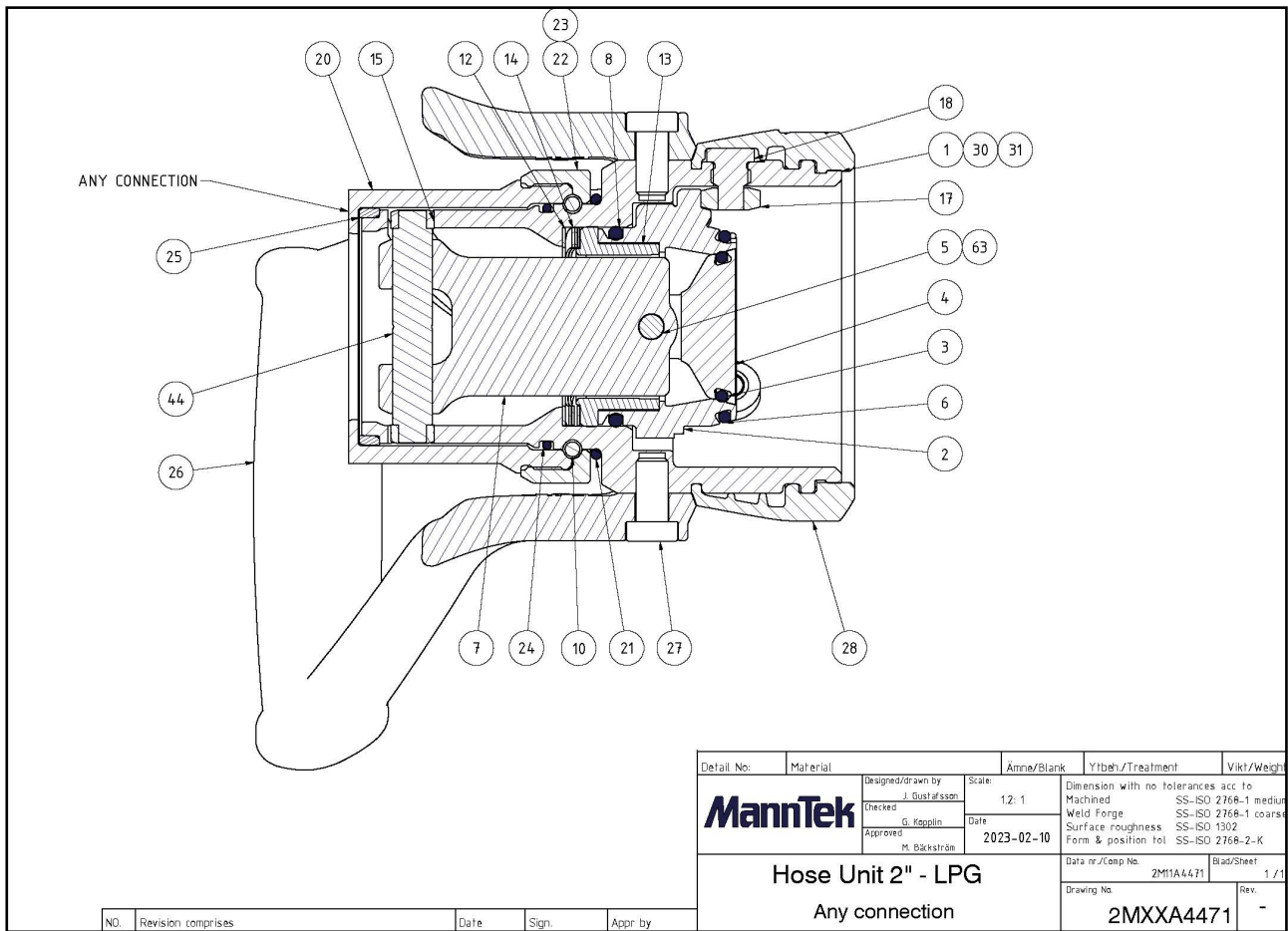

MATERIAL: Stainless Steel

TYPE OF CONNECTION: Threaded and Flanged couplings have the same service instruction.

PERFORM A SERVICE: If leaking or change of media.
According to application service plan,
(see regular service p.4)

PLEASE NOTE

Make sure that you are using the correct material of O-rings and seals for the media you are using. We use a standard silicone based grease which is suitable for most applications, if you are unsure of suitability for your media please contact us.



© Copyright Mann Teknik AB. Mann Teknik AB reserves the right to make changes at any time in prices, materials, specifications and models and to discontinue models without notice or obligations.

ITEMS NEEDED FOR SERVICE

PARTS NEEDED FOR SERVICE: Spare part kit and Sealing kit (for order numbers see the info box at the bottom of this page)

USEFUL TOOLS: Tool 001 (O-Ring Tools)*
Tool 221LPG-4 (Tool for service of inner package)*
2,5 mm Allen Key
5 mm Allen Key
Ø6 mm Pin
Pliers
11mm Wrench

*Can be ordered from MannTek

SPARE PART KIT INCLUDES: 2 pcs. Split bushings
3 pcs. Rollers
3 pcs. Shafts for rollers
1 pc. Screw
1 pc. Teflon ring
1 pc. Split pin

OTHERS: Tool 081 - Flouroflon® grease. (Chemical neutral silicon oil with PTFE. Used for O-rings)*
Tool 086 - CargoFluor® grease (Fluor oil based grease oil with PTFE used for rollaxels.)*
Loctite®

*Can be ordered from MannTek

CLEANING AGENTS: Strong clean® (Petroleum based degreasing agent)
Alcohol (95 % chemical clean ethanol)

PLEASE NOTE

Use only original MannTek spare parts for maintenance

Spare part kit (S-2M-XX)

Sealing kit (O-2M-YY)

yy means the O-ring material key, xx means the coupling material according to the product catalogue. You will find it also as the 6th to 9th sign in the serial number (e.g. 2M11Axyy).



© Copyright Mann Teknik AB. Mann Teknik AB reserves the right to make changes at any time in prices, materials, specifications and models and to discontinue models without notice or obligations.

MAINTENANCE AND SERVICE



Always de-pressurise the system and rinse off the parts before beginning any maintenance work. Use protective goggles. Do not handle O-ring seals without gloves if the material appears charred, gummy or sticky.



Use tweezers and wear neoprene or PVC gloves. Do not touch adjacent parts with unprotected hands. Rinse off the parts once again before starting the "daily inspection".

DAILY INSPECTION

1. Visually inspect the coupling for cleanliness, wear, loose parts, damage and signs of corrosion.
2. Visually inspect the front face of the coupling for wear, dirt and damage.
3. Visually inspect the coupling for leaks.
4. Inspect the hose unit rollers for easy rotation and no signs of seizure. Clean and lubricate if needed.

REGULAR SERVICE

The regular service interval is very much depending on local regulations and application conditions. If nothing else is specified or agreed and it is a new application with unknown parameters we recommend to make a first service after one year and then decide depending on the inspection result about further intervals.

The service procedure shall be as follows:

1. Replace the hose unit O-rings.
2. Replace worn or damaged components.

Check the state of the connection surface and verify that it is clean before proceeding with the connection. Minor scratches on the sealing surfaces can sometimes be polished out.

Couple the serviced hose unit to a usable tank unit as appropriate and check for the correct operation of the valve actuating and bayonet locking mechanism. Couple and uncouple the unit(s) several times.

DISASSEMBLE

- Mark the position of the swivel sleeve against the swivel ring, e.g. by a marking pen, in order to know the correct position for the locking screw.
- Unscrew and remove the lock screw from the swivel ring.

Use an Allen Key 2,5mm



- Rotate the swivel sleeve so that a $\varnothing 6$ mm pin can be inserted in the slot between the housing and the swivel ring.

- Unscrew the swivel sleeve from the swivel ring.

Use a $\varnothing 6$ mm pin



- Remove the Bushing Ring (pos. 25). Sometimes it can be found inside the swivel sleeve.



- Fixate the tool 221LPG-4 from rotation in a vice.
- Put the hose unit on tool 208 and turn it until the rollers are about halfway down the cam curve.

Use tool 221LPG-4



- Remove the two rollers (pos. 15) and the rolling shaft (pos. 44) from the piston guide (pos. 7).



- Rotate the inner package so the three slots in the driving plate match the rollers.
- Remove the inner package by pressing the piston guide from behind. If the driving plate does not loosen easily use a soft tool, e.g. made by rubber, and carefully press the driving plate out.

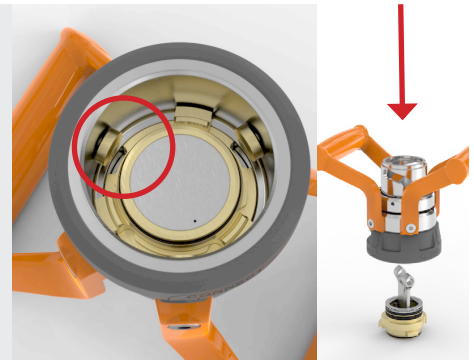

- If you prefer easier access to the O-Rings, remove one or both the handles before you change the O-rings, Not required.

Use an Allen Key 5mm



CHANGE THE SWIVEL SLEEVE SEALS

Make sure you don't scratch any sealing surfaces.

Use the O-ring hook (Tool 001)

- Remove the dust protection O-ring (pos. 21) by using an O-ring hook. The easiest way to get the dust protection O-ring out is to put the hook through the O-ring and pull it out.
- Replace with a new O-ring.

Make sure that the balls are in the correct position before the new O-ring is mounted.



- Remove the swivel O-ring (pos. 24) by using an O-ring hook.
- Replace with a new O-ring. Use Flouroflon® grease on the new O-ring.

Make sure that the O-ring is not twisted.



CHANGE THE INTERNAL SEALS

Make sure you don't scratch any sealing surfaces and that the new O-ring doesn't get twisted.

Use the O-ring tool (Tool 001)

- Remove the O-ring (pos. 8) on the driving plate backside by using an O-ring hook.
- Replace with a new O-ring. Use Flouroflon® grease on the new O-ring and washers.

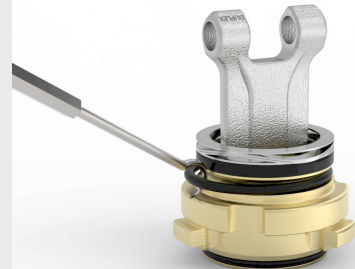

- Remove the O-ring (pos. 6) on the driving plate front side by using an O-ring hook.
- Replace with a new O-ring. Use Flouroflon® grease on the new O-ring.



- Remove the O-ring (pos. 3) on the piston by using an O-ring hook.
- Replace with a new O-ring. Use Flouroflon® grease on the new O-ring.
- Press down the O-Ring with your thumb crosswise so it is stretched equally around the piston. Make sure that the O-Ring is fully pressed into the groove.



CHANGE THE INTERNAL BUSHINGS

- If the piston guide bushings (pos. 13) look worn, they need to be changed.
- Remove the piston guide bushings (pos. 13) supporting the piston.
- Replace with new piston guide bushings.
- If equipped with old bushing ring, this needs to be cut and removed to fit the new bushings.

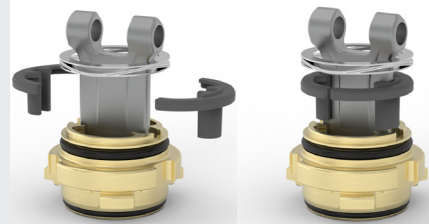

CHANGE THE ROLLERS

- Remove the bumper (pos. 28), by pulling it off the coupling, gripping at the ID plate window.



- To change a roller, unscrew the shaft (pos. 18) using a *11mm wrench*.
- Use some Loctite on the new shaft threads and screw them back into the housing.



- Reassemble the bumper to the coupling.
- Make sure that the cut-out for the ID plate is over the ID plate and make sure that the bumper snaps into place securely.



REASSEMBLE

- If you disassembled the handles, it is now time to reassemble those.
- Use Loctite® to secure the screws. Do not over tighten the screws.

Use an Allen Key 5mm



- Use Cargoflour® grease on the new shaft end, before mounting a new roller.
- Make sure the rollers rotate easily.

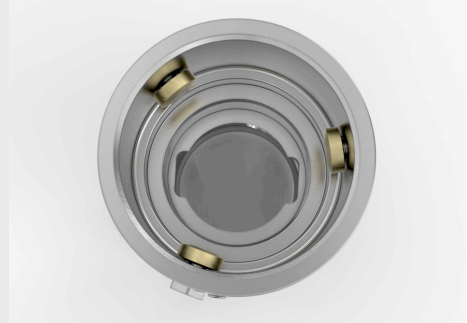

- One of the lugs on the driving plate is aligned with the hole on the piston guide. [a]
- One of the arrows on the bumper is aligned with the upper end position of the cam curve. [b]
- Place the coupling body and inner package according to the picture with all 4 points aligned.
- Place the coupling body over the inner package and grab the piston. Turn the coupling upside down and rotate it until the rollers are above the cut-outs in the driving plate. Place the hose unit on tool 221LPG-4.

Use Tool 221LPG-4

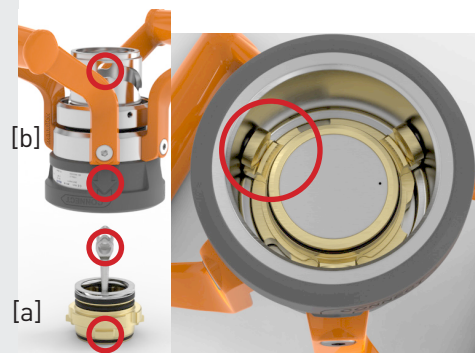

- Mount the rolling shaft (pos. 44) and two new rollers (pos. 15) with the flat side facing inwards into the piston guide. Use Cargoflour® grease both on the inside (towards the shaft) and outside (towards the swivel sleeve).
- Turn the Hose unit until the rollers are in the end position of the cam curve and remove from tool 221LPG-4.

Use Tool 221LPG-4



- Place a new Bushing Ring (pos. 25) with the chamfered outer edge facing upwards on the coupling.
- Double check that the old ring isn't still stuck in the swivel sleeve.



- Put the $\varnothing 6$ mm pin back in the slot to lock the swivel ring.
- Place the swivel sleeve over the coupling body and screw in the swivel sleeve until it is aligned with the pen marking made in the beginning. When the sleeve is in correct position, screw the locking screw into the swivel ring.

NOTE tighten the locking screw with light torque and test the swivel function. Too much torque might deform the swivel ring which causes that the swivel function won't work properly.



TEST THE COUPLING

- Perform a visual inspection ensuring that everything is in its place. Also do a test connection/disconnection with a tank unit that doesn't have any fluid inside.
- Finally, perform a pressure and/or leak test according to the test procedure described on the next page.
- If the coupling functions correctly you are ready to mount the hose unit in your application again.



TEST PROCEDURE

After each major service a pressure test and a leak test of each coupling is required.

If only the O-Ring kit is replaced a leak test is enough.

If any pressure bearing parts are changed, a pressure test with water must first be made at 1,5 times the working pressure before testing the coupling with air for the leak test.

The following test parameters are in accordance with EN12266 and EN14432:

TEST PROCEDURE	TEST PRESSURE	ACCEPTANCE CRITERIA
Leak test (air)	0,3 bar	No visually detectable leakage for the duration of the test*
	6 bar	
Pressure test (water) (if applicable)	1,5x working pressure	

TABLE 1 – TEST PRESSURE

NOMINAL SIZE	MINIMUM TEST DURATION
Up to DN 50	15 s
DN 65 to DN 150	60 s

TABLE 2 – MINIMUM TEST DURATION

TEST PROCEDURE:

- Plug the hose unit with the appropriate end connection and fill it with the test media (e.g. air or water).
- Apply the test pressure specified in Table 1 (please note that for a seal leak test, both a low pressure and a high pressure test are required).
- Maintain the test pressure for the keeping time specified in table 2.
- Make sure that there is no visually detectable leakage.
- Couple the serviced hose unit to a usable tank unit and test for leakage.
- After successful test results dry the coupling before use.

* In order to detect leakage when testing with air, make sure to fully submerge the sealing surface in water. Initial leakage might be due to air trapped behind the seal and is acceptable. Reoccurring bubbles indicate a leak.

STORAGE

Store coupling in a dry, dust free, dark place, in ambient temperature.