

SERVICE INSTRUCTION

# CBC

3" - E-Version



VERSION: 250813

**MannTek**

# CBC – E-VERSION – 3”

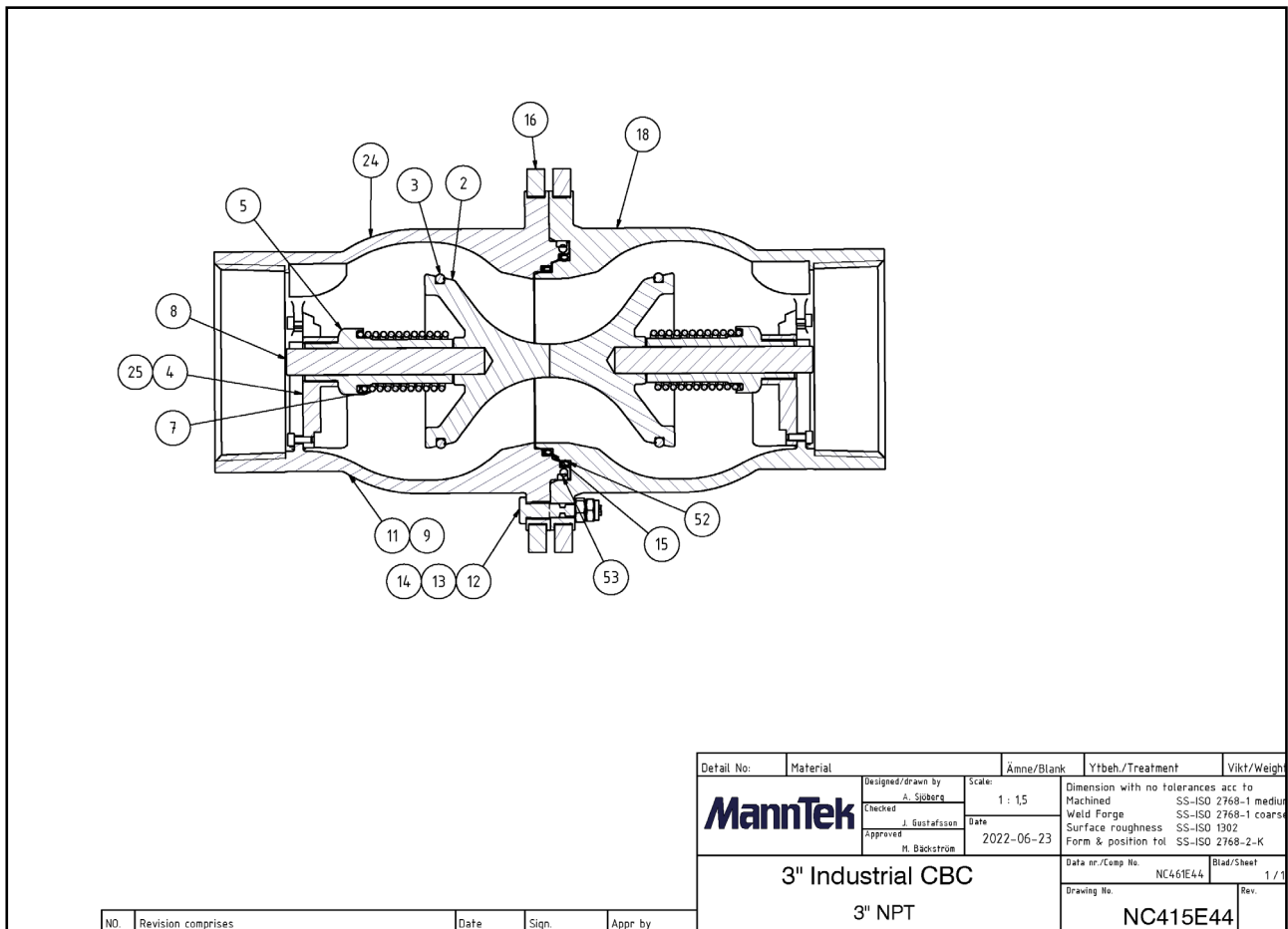

**MATERIAL:** Stainless Steel

**TYPE OF CONNECTION:** Threaded and Flanged couplings have the same service instruction.

**PERFORM A SERVICE:** If leaking  
According to application service plan,  
(see regular service p.4)  
If change of media

## PLEASE NOTE

Make sure that you are using no grease for cryogenic applications



© Copyright Mann Teknik AB. Mann Teknik AB reserves the right to make changes at any time in prices, materials, specifications and models and to discontinue models without notice or obligations.

## ITEMS NEEDED FOR SERVICE

**PARTS NEEDED FOR SERVICE:** Spare part kit and Sealing kit (for order numbers see the info box at the bottom of this page)

**TOOLS NEEDED:** Tool 001 (O-Ring Tools)  
Tool 020  
Wrench  
Allen Key

**BOLT KIT INCLUDES:** 3 pcs. Breaking Bolts  
3 pcs. Nuts  
3 pcs. Locking Nuts

**OTHERS:** Loctite 2700® Thread locker.

**CLEANING AGENTS:** Strong clean® (Petroleum based degreasing agent)

### PLEASE NOTE

**Use only original MannTek spare parts for maintenance**

Bolt kit (S-N4D-44-XX)

Sealing kit (O-NC4E)



XX refers to the braking force of the breaking bolts, which can be found either on the original bolts or on the ID plate.

© Copyright Mann Teknik AB. Mann Teknik AB reserves the right to make changes at any time in prices, materials, specifications and models and to discontinue models without notice or obligations.

## MAINTENANCE AND SERVICE



Always de-pressurise the system and rinse off the parts before beginning any maintenance work. Use protective goggles.



Use tweezers and wear neoprene or PVC gloves. Do not touch adjacent parts with unprotected hands. Rinse off the parts once again before starting the “daily inspection”.

## DAILY INSPECTION

1. Visually inspect the coupling for cleanliness, wear, loose parts, damage and signs of corrosion.
2. Visually inspect the coupling for leaks.

## REGULAR SERVICE

Regular service interval is very much depending on local regulations and application conditions. If nothing else is specified or agreed and it is a new application with unknown parameters we recommend to make a first service after one year and then decide depending on the inspection result about further intervals.

The service procedure shall be as follows:

1. Replace seals at least once a year.
2. Replace worn or damaged components..

## AFTER RELEASE

When the coupling should go into service there is a danger that the fluid will spurt out. Special protective measures such as personal protective equipment must therefore be adopted. Always ensure the system is cleaned in a proper manner. After cleaning, remove any residue from the cleaning agent.

- a) Wear suitable personal protective equipment.
- b) Make sure that the coupling is de-pressurised and empty.
- c) Clean coupling before disassembly (use cleaning agent suitable for the pumped fluid).



## DISASSEMBLE

Screw out the destroyed parts of the breaking bolts.

Check for dirt, seal damage and any obvious physical damage (such as impacts, etc.).



Unscrew the three screws that lock the spindle steering.

There is a distance pin in the piston protruding from the housing.

For disassembling a support plate with a hole in the middle, where the distance pin will get free, will avoid any damage of the inner parts

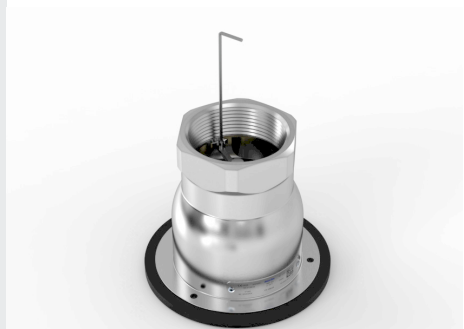

Press down the spindle steering and turn it free. Release it carefully.

Piston guide is spring loaded. Risk of injury.

Using our special tool makes work easier and therefore increases safety.

Repeat the same procedure with the second half.



## DETAIL PARTS AFTER DISASSEMBLING

Take out all the parts from the body

Pos.2 – Piston

Pos.5 – Spring cap

Pos.7 – Spring

Pos.4 – Spindle steering

Pos.18 – Body



## PISTON O-RING

Replace the O-ring (pos.3) on the piston with a new O-ring.

Be careful when removing the O-ring. Do not scratch the sealing surface.

Make sure that the seal doesn't get scratched when mounting.

For mounting the new O-ring use MannTek spare parts only.



## MOUNTING PISTON

The piston is bigger in diameter than the three brackets for the piston guide.

Introduce the piston as shown. Put it into a relaxing position in the valve seat. Take care; the piston is sticking out on the other side.

For assembling a support plate with a hole in the middle will be helpful.

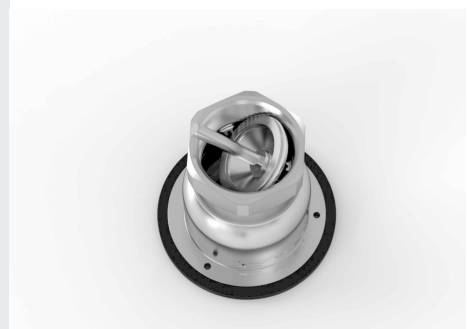

## REASSEMBLE COUPLING HALVES

Fit the spring with spring cap and spindle steering with guidance bushing. Press down the spindle steering and turn, to fix it in its position.



Fit the screws into the given holes in the body and fix the spindle steering by mounting the three locking screws. Use Loctite® 2700 for locking the screws.

Repeat the same procedure with the second half.



## OUTER BODY SEALING RING

Replace the sealing rings (pos.15, pos.50, pos.51, pos.52, pos.53) on the body with a new one.

Be careful when removing the lip-seal. Do not scratch the sealing surface.

Make sure that the seal is not scratched during installation. The open profile should face downwards, as shown in the picture. The sealing ring at pos.15 may be supplied with a pre-mounted distance ring. If so, it is important to keep the distance ring when fitting the seal.

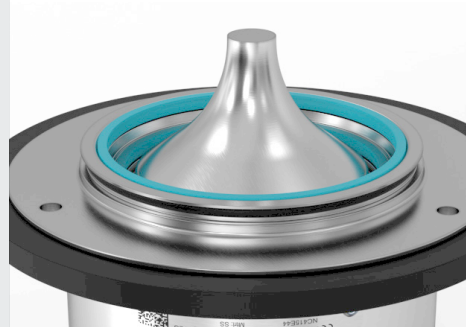

## BREAKING BOLTS

Replace the bolts only by original spare parts from MannTek with the same breaking force.

Total break force for the bolts can be found on the head of each bolt. (E.g. 13 kN in the pictures)

Left: destroyed bolt after release

Right: new breaking bolt

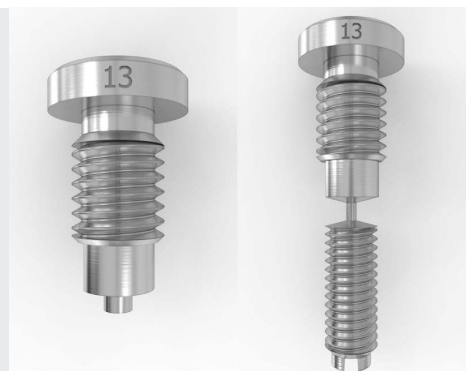

## REASSEMBLE COUPLING

Fit the spring with spring cap and spindle steering with guidance bushing. Press down the spindle steering and turn, to fix it in its position.



Set both halves onto each other and press them carefully together. The breaking pins should align to the bore holes in the second half.

It is important that the bodies align to each other when pressing the halves together. Do it carefully, not to destroy the lip-seal.

Using a press and a fixture makes work easier.



Screw on the nuts by hand until stop when halves are pressed together.

Do not use force for tightening! Risk of destroying bolts.



Fasten it a little bit with a wrench, max 45 degrees.

It is important that all 3 bolts are mounted in the same way. Risk that one bolt will be destroyed before the others.

*Standard wrench 24mm*



Screw on the second nut and lock the first one. Hold the first one with a wrench to avoid forces on the breaking bolt.



## TEST THE COUPLING

Perform a visual inspection ensuring that everything is in its place. Finally, do a tightness test according to the test procedure described on the next page.

If the coupling functions correctly you are ready to mount the CBC back in your application again.



# TEST PROCEDURE

After each major service a leak test of each coupling is required.

The following test parameters are in accordance with EN12266, EN14432 and ISO5208:

TEST PROCEDURE	TEST PRESSURE	STOP TIME
Tightness test (air/N2)	6 bar +/- 1 bar*	60 s

TABLE 1 – TEST PRESSURE

Instead of dry air/N2 we recommend making the tightness test with liquid nitrogen or with LNG.

If a pressure test should be achieved for the coupling mounted in an assembly follow the respective text instructions for the equipment but do not exceed our recommended maximum test pressure of the coupling which you will find in table 2. If testing with higher pressure is necessary, please ask our sales department for a special test bolt kit.

It is not recommended to use liquids for the tests which will freeze under operation with LNG. If so it must be guaranteed that the coupling is completely free of liquid before it will be used in operation.

## TEST PROCEDURE:

- Cool down the coupling by letting the test medium flow through until the coupling bodies are cooled down (the couplings should be completely covered by ice powder from condensed water from the air). Internal pressure should be 5-7 bar.
- Verify that there is no visible leakage between the coupling halves.

## STORAGE

Store coupling in a dry, dust free, dark place, in ambient temperature.