

Aviation

Fuelling Equipment



***Sampling, Vent
or Drain unit***

Product Information

About Mann Tek

Mann Teknik AB is a Swedish company located in Mariestad, Sweden.

Mann Teknik AB produces and markets products for safe and environmentally friendly handling of aggressive fluids for the chemical and petrochemical industries.

The main product is the Dry Disconnect Couplings, DDCouplings®, for spill free liquid handling. The products are marketed through independent representatives in more than 30 countries.

Mann Teknik AB have many years of experience in designing, producing and marketing of DDCouplings® all since 1977.

Mann Teknik AB has shown a high rate of growth during the past years and is now a major player in its specialised field of operation. This is due to a determined expansion into growing markets and recognition by customers of the robust design and reliable quality of the products.

Mann Teknik AB are certified to ISO9001:2000. The products are CE-labeled. The main products are certified to PED, the European Pressure Equipment Directive and ATEX, the European directive for Equipment intended for use in Potentially Explosive Atmospheres.

The products are produced in accordance with several important standards, e.g. the NATO STANAG 3756

KilltheSpill

Contents

Company information	2
General information - Sampling, Vent or Drain unit	3
Applications, Note and Operation procedure	4-5
Tank Unit with Pressure Relief and Equalizing Valve	6
Options - Flange with Dip Pipe	6
Options - Dust Cap	7
Technical Data	7
Product range table	8
Sampling, Vent or Drain Unit - Stainless Steel	9-15
- Carbon Steel	16-22
Tank Unit with standard flange Flange Connection	23-24 25
Flange Measurement	26-27
Other Products, Approvals and Your distributor	28



Why use the Mann -Tek Sampling, Vent or Drain Units?

- Take a sample to check the quality of fuel in a hydrant system on airports.
- Draining of condensate and venting out of hydrant systems.
- Preventing pressure drop while sampling by lock valves with fire safe function.
- Fits into standard 18" external pipe pits with ANSI 6" 300 psi flange.
- "Easy to Use" – design saves time and minimizes health risks.
- Reliability and easy servicing saves your investment.
- Approved for safe handling by independent "Notified Body".
- Connection by 70 mm dry disconnect coupling acc to STANAG 3756.
- Dry disconnect coupling equipped with built in Pressure Relief and Bleeding Valve function.



Application

Modern airports are using an underground pipeline, for the fuelling of aircrafts. Mobile dispensers are the interface between this hydrant system and the airplane.

They are containing pumps, valves, hoses and couplings to pump the fuel from the hydrant system to the plane.

The pipelines are designed with high points, low points and convenient points. If there is condensate in the pipeline, which is heavier than the fuel, it will sink to the low points.

Encapsulated air will rise to the high points. Neither water nor air is very welcome in the pipeline.

To get them out of the pipeline there are sampling units at each low point for draining and at each high point for venting.

At the convenient point the sampling units are used to take samples of the fuel to check the quality.



Applications

- **Sampling** - installed at a convenient point on a riser from the main hydrant line
- **Venting** - installed at a high point in the hydrant line
- **Draining** - installed at a low point in the hydrant line

Note

- Only one operation handle is supplied for Ball Valves. The lower Valve is left open at all times unless the upper Valve is to be removed for service.
- Upper Valve must be fully closed before operating.

Operation procedure

1. Ensure upper Valve is fully closed
2. Remove Dust Cap.
3. Connect 2" Hose Unit to the Tank Unit. With exceptionally high pressure, after i.e. thermal expansion, the overpressure equalizes automatically after few seconds. The coupling procedure can then be continued.

IMPORTANT: The overpressure/medium is kept within the system

4. Open Upper Valve
5. Take required sample (or Vent/Drain).
6. Fully close Upper Valve.
7. Uncouple Hose Unit
8. Replace Dust Cap

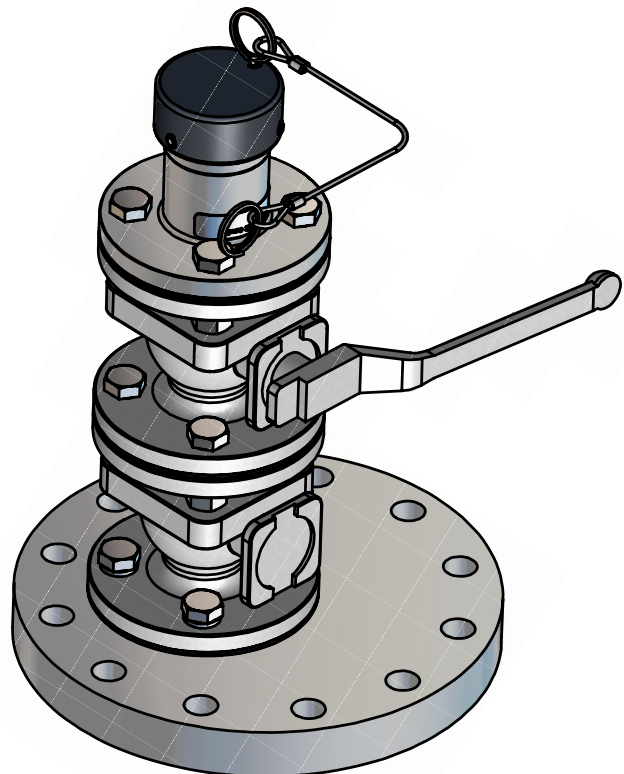

Tank Unit with Pressure Relief and Equalizing Valve

Pressure differences in the system reduces by the piston stroke forward or backward

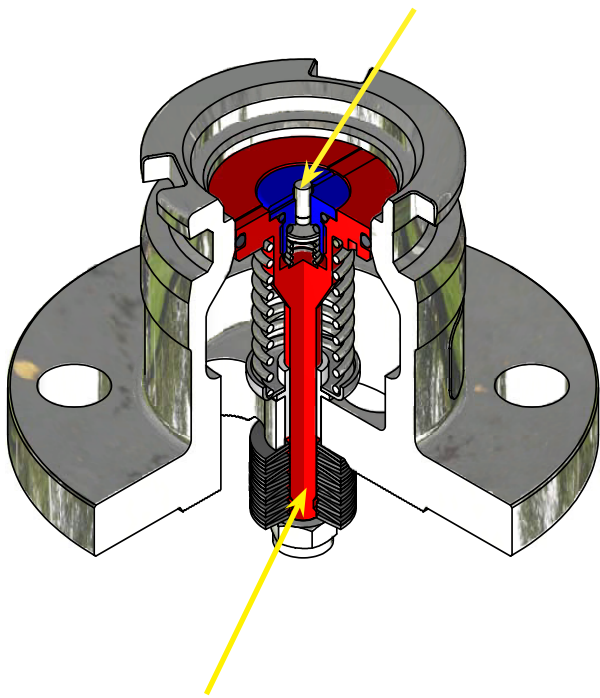

Function: When you start to connect the Hose unit (coupler), the Hose unit piston moves forward and pushes on the pressure equalizing valve piston.

Now the pressure equalizing valve is open and the pressure between the Tank unit and the Hose unit is equalized. Then you have no problem to proceed with the connection.

You will not have problems to connect the Hose unit when there is fluid under high pressure in the Tank unit or if there is incompressible fluid caught between the valve and the Tank unit.

Pressure Relief Valve opens at a predetermined pressure at an acceptable and riskless limit

Option - Flange with Dip Pipe

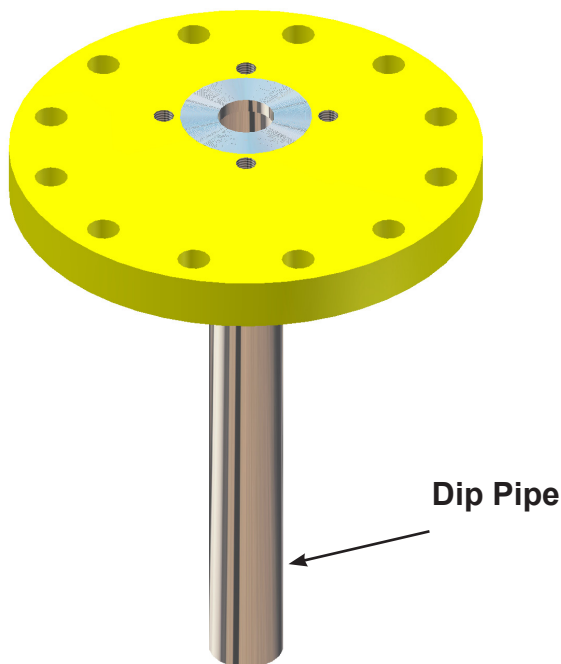

Flange with Dip Pipe is used for draining water when it's placed at a low point

Option - Dust Cap for Tank Unit

A Dust Cap should be used to prevent the ingress of dirt or water

Composite

Patent No. 000840780-0001

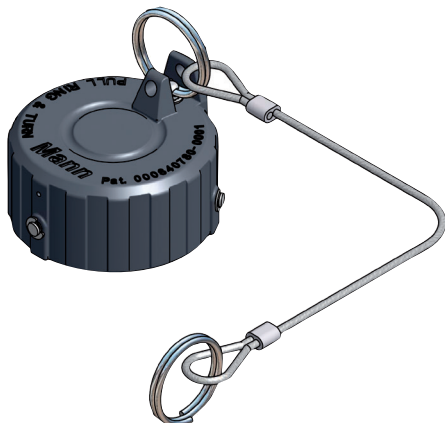

Rubber



Code nr:	Material:
C200E2202	Composite ^{1) 2)}
C200D1301	Rubber (NBR)

- 1) Lowest operation temperature is -20°C / -4°F
 2) Seals in FPM (Standard Viton®). Other materials on request.

Viton® is a registered trademark of DuPont.

Technical Data

Materials: Stainless Steel SS-EN 10 272-1.4404+AT (AISI 316L)
 Ball Valve in 1.0619 and 1.4301

Seals: FPM (Standard Viton®). NBR (Nitrile®).
 Other on request.

Lowest Operation Temperature :

With Seals Material:	Lowest Temperature:
FPM (Standard Viton®)	-20° C / -4° F
NBR	-25° C / -13° F
Low temperature NBR	-40° C / -40° F

Max working pressure: 20,7 bar / 300 psi

Min burst pressure: 62,1 bar / 900 psi

Operation pressure relief valve: 20 bar +/- 2 bar

Connection to pipeline: Flange 6" ANSI B16.5 300 psi

Tank Unit Connection to Hose Unit: STANAG 3756 (70 mm)

Viton® is a registered trademark of DuPont.

No part of this leaflet may be reproduced in any form or by any means without permission in writing from the publisher.

Sampling, Vent or Drain Unit - Product range table

Complete with pressure relief and equalizing Valve.

Tank Unit		Ball Valve with flange connection	Flange	Lenght	Weight	Code No. Stainless Steel
Socket Ø	Flange Inch/ DN					Code No. Carbon Steel
70 mm	2"	2 pcs	2" ANSI	477 mm 18.78 inch	21 kg 46 lbs	H257A4401QE
		2" ANSI Reduced bore diam. (1½")				H257A3301QE
70 mm	1½"	2 pcs	6" ANSI	453 mm 17.83 inch	40 kg 88 lbs	H255F4401QE
		1½" ANSI Reduced bore diam. (1¼")				H255F3301QE
70 mm	DN 40	1 pcs	6" ANSI	299 mm 11.77 inch	34 kg 75 lbs	H227F4401SE
		DN 40 Full bore diam. (40 mm)				H227F3301SE
70 mm	DN 40	2 pcs	6" ANSI	440 mm 17.32 inch	40 kg 88 lbs	H227F4401E
		DN 40 Full bore diam. (40 mm)				H227F3301E
70 mm	DN 50	1 pcs	6" ANSI	309 mm 12.17 inch	37 kg 81 lbs	H230F4401SE
		DN 50 Full bore diam. (50 mm)				H230F3301SE
70 mm	DN 50	2 pcs	6" ANSI	460 mm 18.11 inch	46 kg 101 lbs	H230F4401E
		DN 50 Full bore diam. (50 mm)				H230F4401E
70 mm	2"	2 pcs	6" ANSI	440 mm 17.32 inch	40 kg 88 lbs	H257F4401E
		2" ANSI Full bore diam. (2")				H257F3301E

O-rings in FPM (Viton®). Other materials on request.

Viton® is a registered trademark of DuPont.

Sampling, Vent or Drain Unit in Stainless Steel

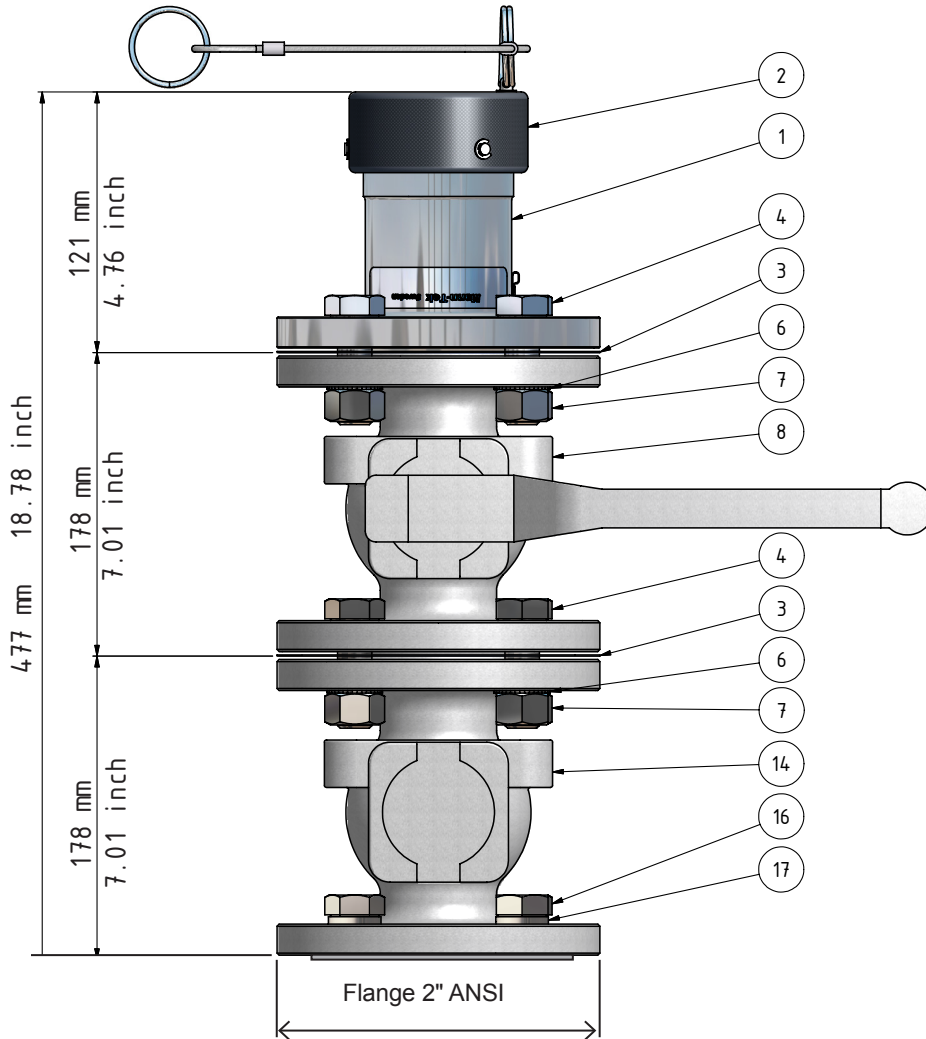

Code No: H257A4401QE

Pos.	Description	Material
①	Tank Unit	Stainless Steel
②	Dustcap	Composite
③	Gasket	Klingerit
④	Bolt M16x50	A2 (SS)
⑥	Washer	A2 (SS)
⑦	Nut M16	A2 (SS)
⑧	Ball Valve with Handle	Stainless Steel
⑭	Ball Valve without Handle	Stainless Steel
⑯	Bolt M16x40	A2 (SS)
⑰	Wavy Washer	Stainless Steel

Complete with Pressure Relief and Equalizing Valve
Ball Valve - reduced bore diameter (1½")

Working pressure:	20,7 bar / 300 psi
Operation relief valve:	20 bar +/- 2 bar
Test pressure:	31 bar / 450 psi
Min burst pressure:	62,1 bar / 900 psi
Temperature range:	-30 - +200°C / -20 - +392°F

No part of this leaflet may be reproduced in any form or by any means without permission in writing from the publisher.

Sampling, Vent or Drain Unit in Stainless Steel

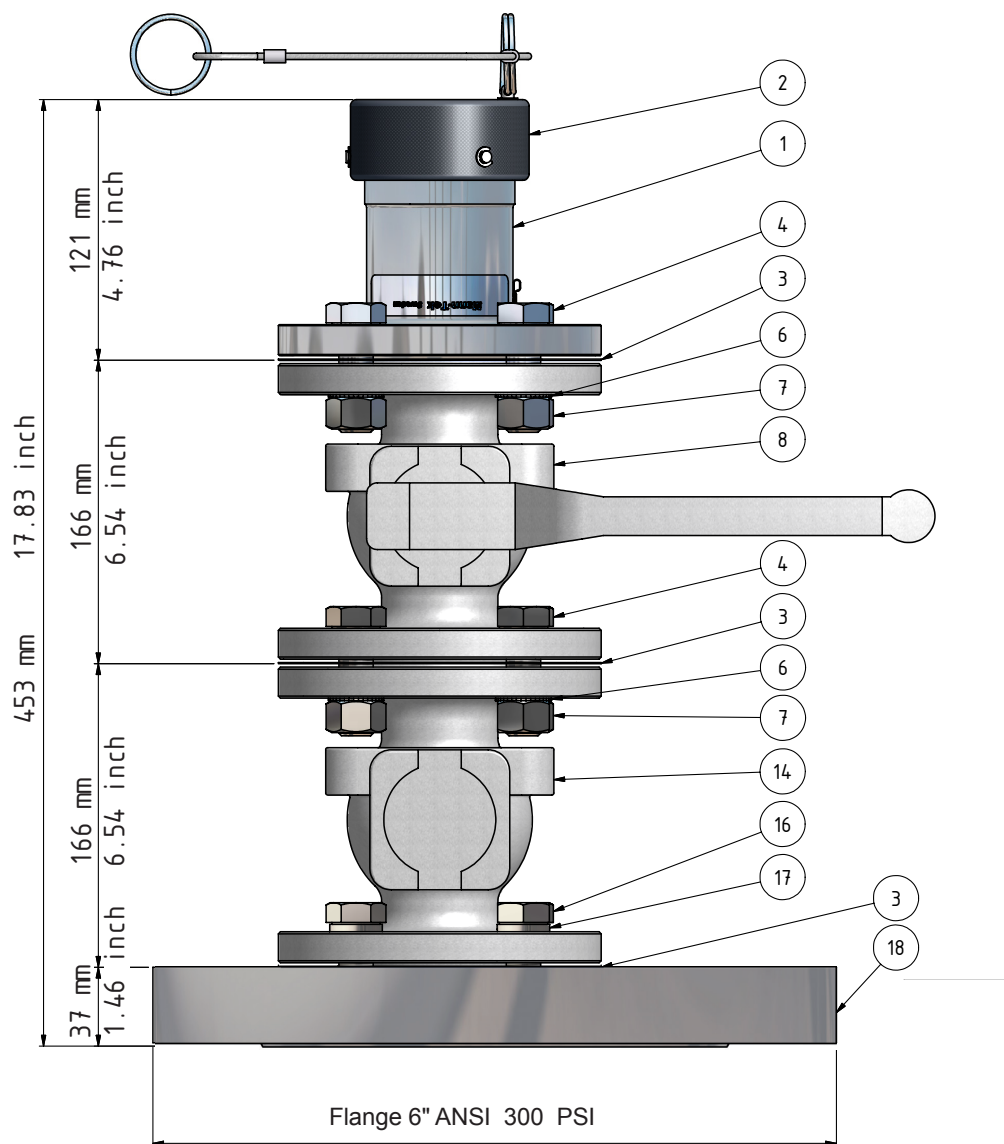

Code No: H255F4401QE

Pos.	Description	Material
①	Tank Unit	Stainless Steel
②	Dustcap	Composite
③	Gasket	Klingerit
④	Bolt M16x50	A2 (SS)
⑥	Washer	A2 (SS)
⑦	Nut M16	A2 (SS)
⑧	Ball Valve with Handle	Stainless Steel
⑭	Ball Valve without Handle	Stainless Steel
⑯	Bolt M16x40	A2 (SS)
⑰	Wavy Washer	Stainless Steel
⑱	Flange 6" ANSI 300 PSI	Stainless Steel

Complete with Pressure Relief and Equalizing Valve
Ball Valve - reduced bore diameter (1¼")

Working pressure:	20,7 bar / 300 psi
Operation relief valve:	20 bar +/- 2 bar
Test pressure:	31 bar / 450 psi
Min burst pressure:	62,1 bar / 900 psi
Temperature range:	-30 - +200°C / -20 - +392°F

Sampling, Vent or Drain Unit in Stainless Steel

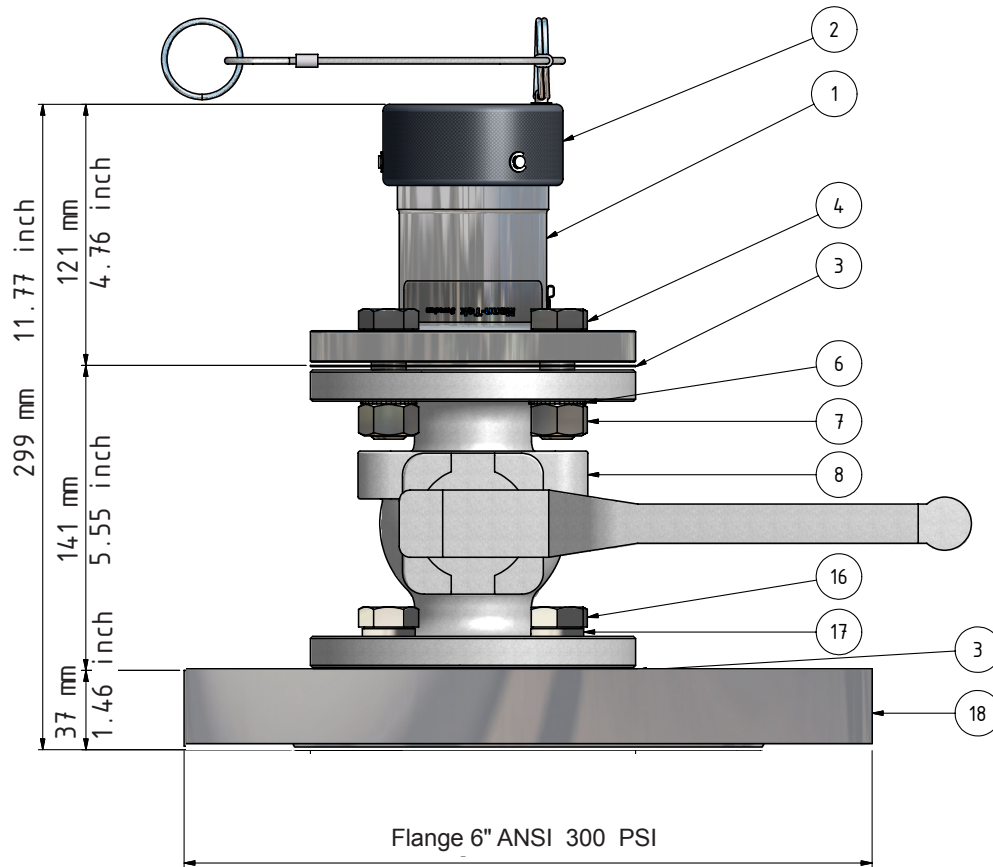

Code No: H227F4401SE

Pos.	Description	Material
①	Tank Unit	Stainless Steel
②	Dustcap	Composite
③	Gasket	Klingerit
④	Bolt M16x50	A2 (SS)
⑥	Washer	A2 (SS)
⑦	Nut M16	A2 (SS)
⑧	Ball Valve with Handle	Stainless Steel
⑭	Ball Valve without Handle	Stainless Steel
⑯	Bolt M16x40	A2 (SS)
⑰	Wavy Washer	Stainless Steel
⑱	Flange 6" ANSI 300 PSI	Stainless Steel

Complete with Pressure Relief and Equalizing Valve

Ball Valve - full bore diameter (40 mm)

Working pressure:	20,7 bar / 300 psi
Operation relief valve:	20 bar +/- 2 bar
Test pressure:	31 bar / 450 psi
Min burst pressure:	62,1 bar / 900 psi
Temperature range:	-30 - +200°C / -20 - +392°F

Sampling, Vent or Drain Unit in Stainless Steel

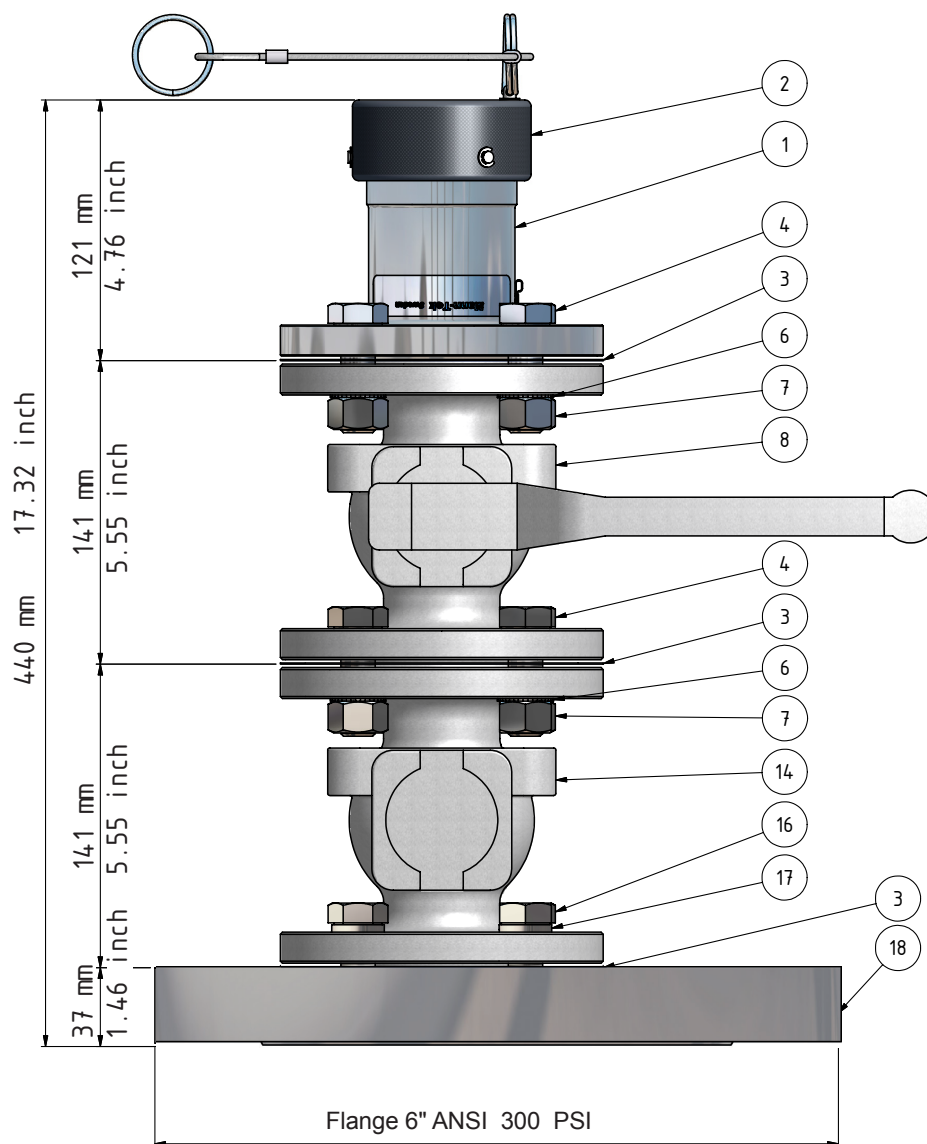

Code No: H227F4401E

Pos.	Description	Material
1	Tank Unit	Stainless Steel
2	Dustcap	Composite
3	Gasket	Klingerit
4	Bolt M16x50	A2 (SS)
6	Washer	A2 (SS)
7	Nut M16	A2 (SS)
8	Ball Valve with Handle	Stainless Steel
14	Ball Valve without Handle	Stainless Steel
16	Bolt M16x40	A2 (SS)
17	Wavy Washer	Stainless Steel
18	Flange 6" ANSI 300 PSI	Stainless Steel

Complete with Pressure Relief and Equalizing Valve
Ball Valve - full bore diameter (40 mm)

Working pressure:	20,7 bar / 300 psi
Operation relief valve:	20 bar +/- 2 bar
Test pressure:	31 bar / 450 psi
Min burst pressure:	62,1 bar / 900 psi
Temperature range:	-30 - +200°C / -20 - +392°F

Sampling, Vent or Drain Unit in Stainless Steel

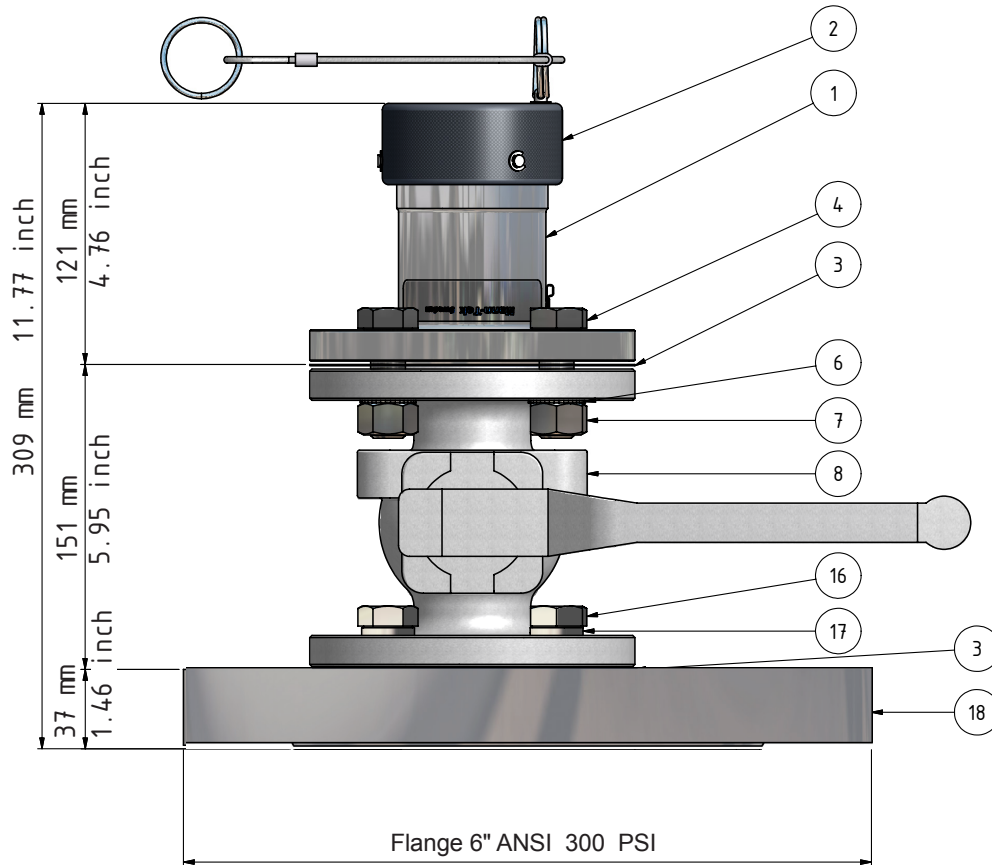

Code No: H230F4401SE

Pos.	Description	Material
①	Tank Unit	Stainless Steel
②	Dustcap	Composite
③	Gasket	Klingerit
④	Bolt M16x50	A2 (SS)
⑥	Washer	A2 (SS)
⑦	Nut M16	A2 (SS)
⑧	Ball Valve with Handle	Stainless Steel
⑭	Ball Valve without Handle	Stainless Steel
⑯	Bolt M16x40	A2 (SS)
⑰	Wavy Washer	Stainless Steel
⑱	Flange 6" ANSI 300 PSI	Stainless Steel

Complete with Pressure Relief and Equalizing Valve

Ball Valve - full bore diameter (50 mm)

Working pressure:	20,7 bar / 300 psi
Operation relief valve:	20 bar +/- 2 bar
Test pressure:	31 bar / 450 psi
Min burst pressure:	62,1 bar / 900 psi
Temperature range:	-30 - +200°C / -20 - +392°F

Sampling, Vent or Drain Unit in Stainless Steel

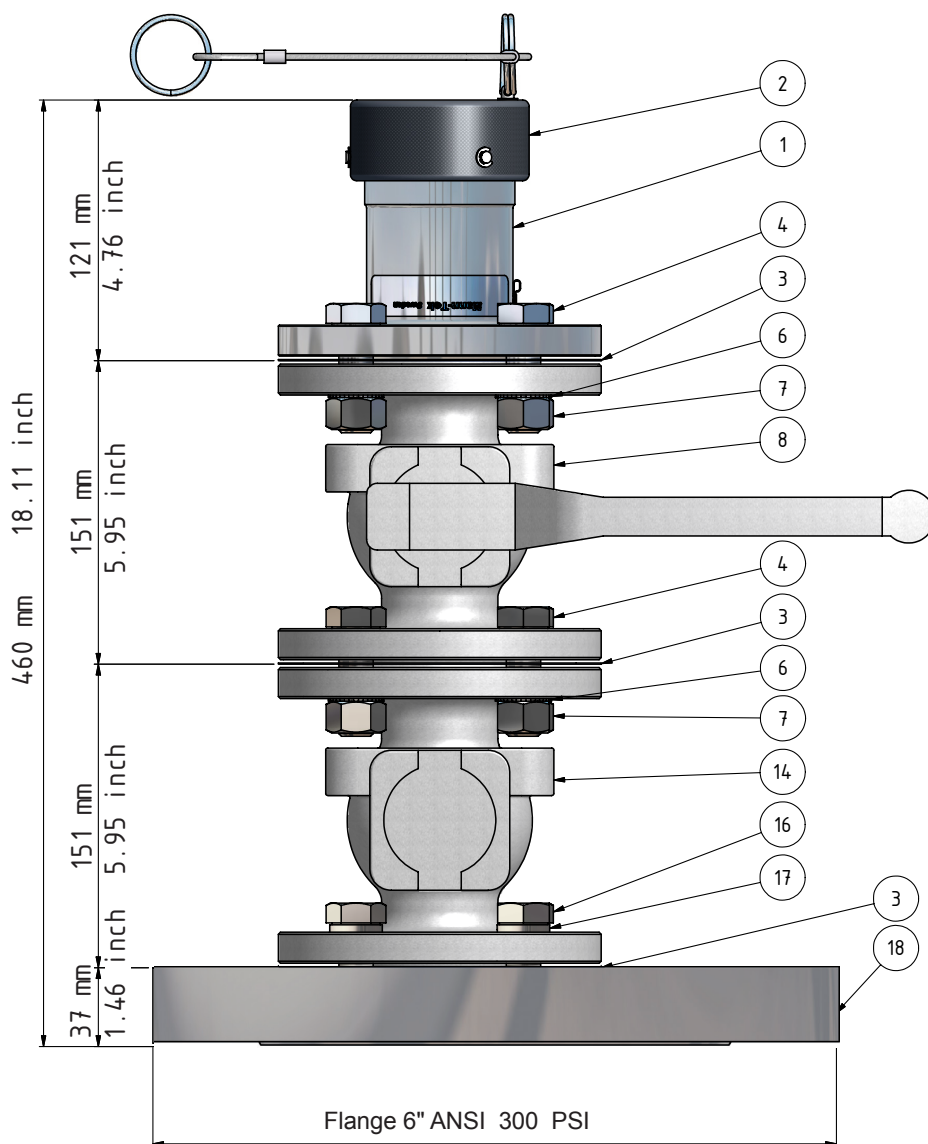

Code No: H230F4401E

Pos.	Description	Material
①	Tank Unit	Stainless Steel
②	Dustcap	Composite
③	Gasket	Klingerit
④	Bolt M16x50	A2 (SS)
⑥	Washer	A2 (SS)
⑦	Nut M16	A2 (SS)
⑧	Ball Valve with Handle	Stainless Steel
⑭	Ball Valve without Handle	Stainless Steel
⑯	Bolt M16x40	A2 (SS)
⑰	Wavy Washer	Stainless Steel
⑱	Flange 6" ANSI 300 PSI	Stainless Steel

Complete with Pressure Relief and Equalizing Valve
Ball Valve - full bore diameter (50 mm)

Working pressure:	20,7 bar / 300 psi
Operation relief valve:	20 bar +/- 2 bar
Test pressure:	31 bar / 450 psi
Min burst pressure:	62,1 bar / 900 psi
Temperature range:	-30 - +200°C / -20 - +392°F

Sampling, Vent or Drain Unit in Stainless Steel

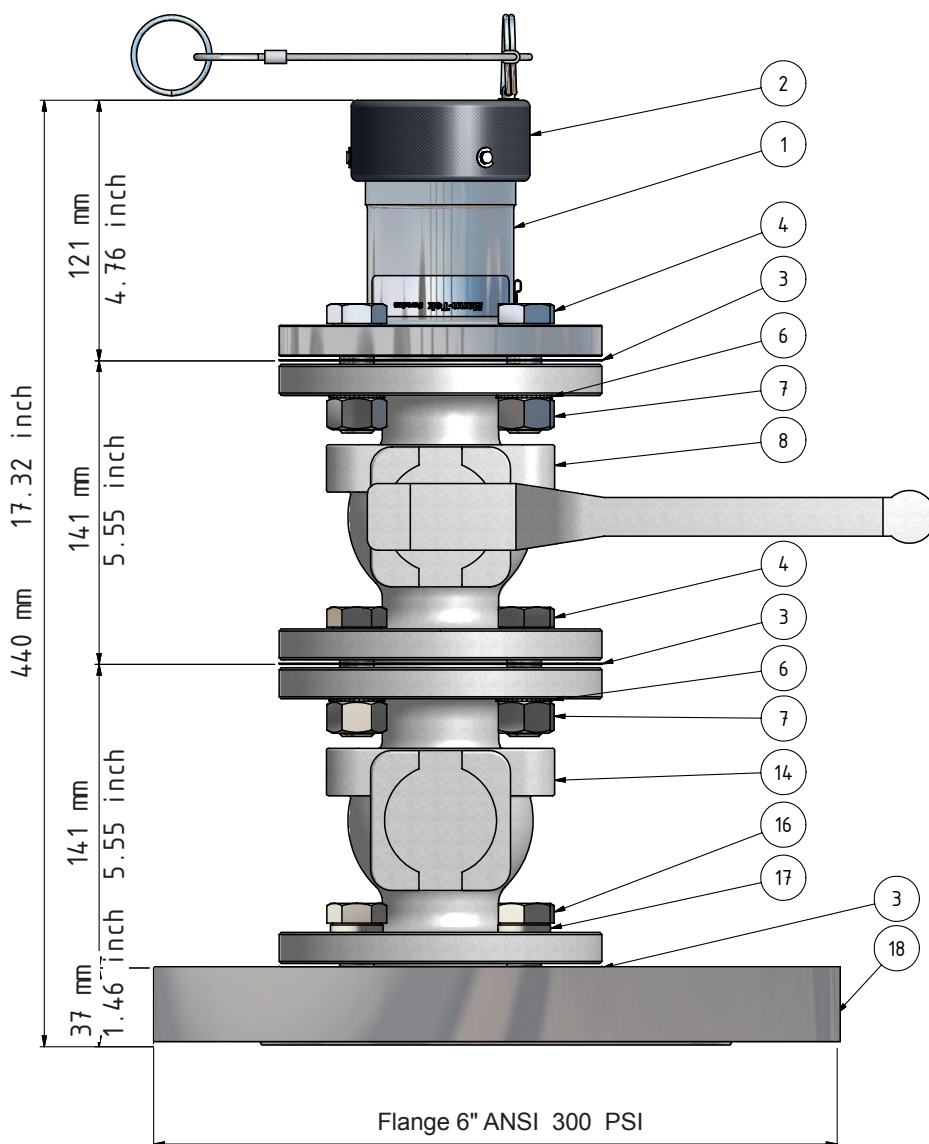

Code No: H257F4401E

Pos.	Description	Material
①	Tank Unit	Stainless Steel
②	Dustcap	Composite
③	Gasket	Klingerit
④	Bolt M16x50	A2 (SS)
⑥	Washer	A2 (SS)
⑦	Nut M16	A2 (SS)
⑧	Ball Valve with Handle	Stainless Steel
⑭	Ball Valve without Handle	Stainless Steel
⑯	Bolt M16x40	A2 (SS)
⑰	Wavy Washer	Stainless Steel
⑱	Flange 6" ANSI 300 PSI	Stainless Steel

Complete with Pressure Relief and Equalizing Valve
Ball Valve - full bore diameter (2")

Working pressure:	20,7 bar / 300 psi
Operation relief valve:	20 bar +/- 2 bar
Test pressure:	31 bar / 450 psi
Min burst pressure:	62,1 bar / 900 psi
Temperature range:	-30 - +200°C / -20 - +392°F

No part of this leaflet may be reproduced in any form or by any means without permission in writing from the publisher.

Sampling, Vent or Drain Unit in Carbon Steel

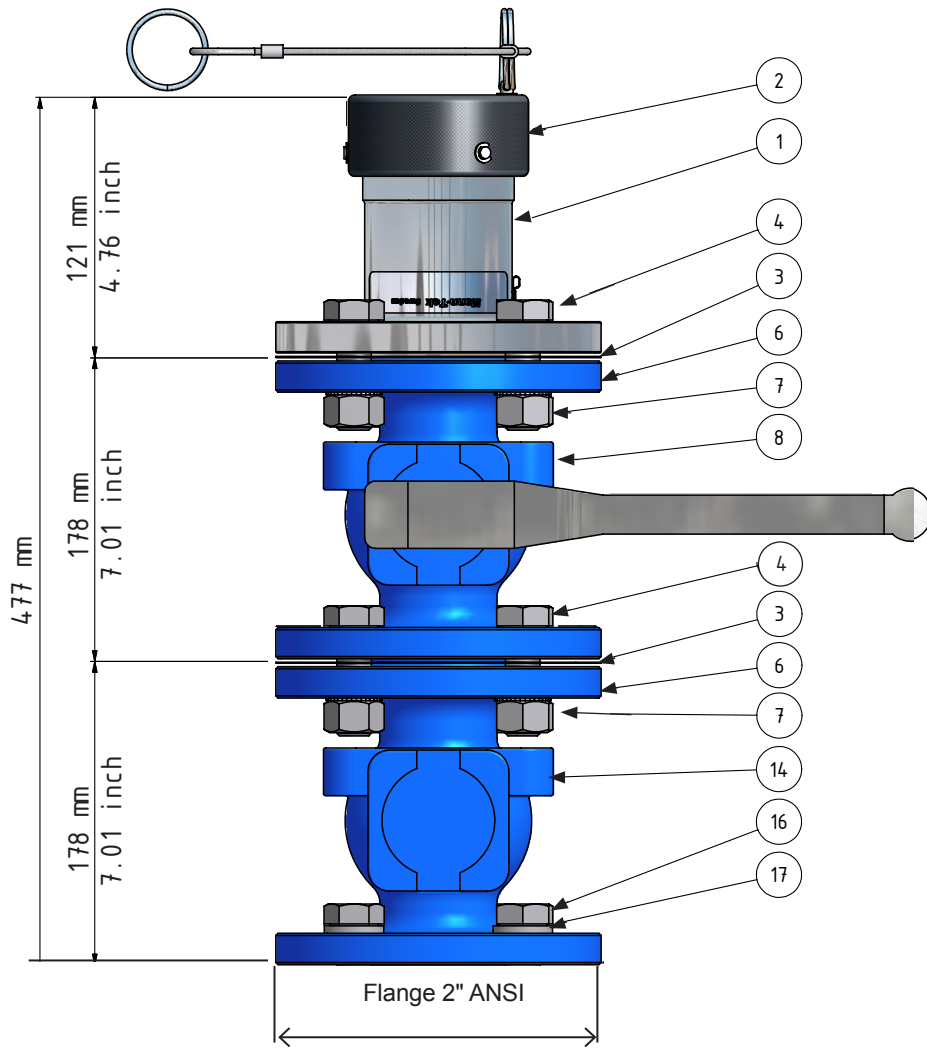

Code No: H257A3301QE

Pos.	Description	Material
①	Tank Unit	Stainless Steel
②	Dustcap	Composite
③	Gasket	Klingerit
④	Bolt M16x50	A2 (SS)
⑥	Washer	A2 (SS)
⑦	Nut M16	A2 (SS)
⑧	Ball Valve with Handle	Carbon Steel
⑭	Ball Valve without Handle	Carbon Steel
⑯	Bolt M16x40	A2 (SS)
⑰	Wavy Washer	Stainless Steel

Complete with Pressure Relief and Equalizing Valve

Ball Valve - reduced bore diameter (1½")

Working pressure:	20,7 bar / 300 psi
Operation relief valve:	20 bar +/- 2 bar
Test pressure:	31 bar / 450 psi
Min burst pressure:	62,1 bar / 900 psi
Temperature range:	-30 - +200°C / -20 - +392°F

Surface treatment: Epoxy Coated

Sampling, Vent or Drain Unit in Carbon Steel

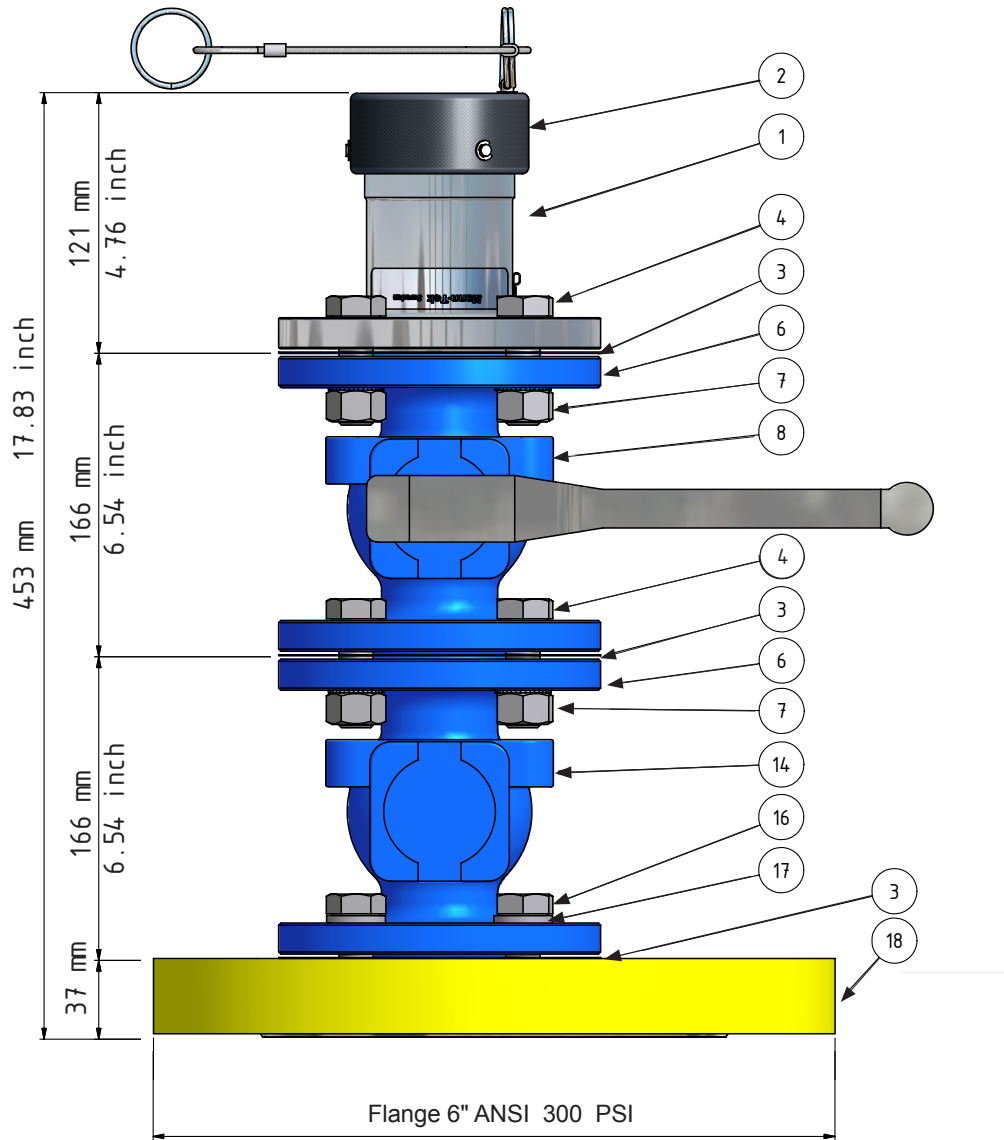

Code No: H255F3301QE

Pos.	Description	Material
①	Tank Unit	Stainless Steel
②	Dustcap	Composite
③	Gasket	Klingerit
④	Bolt M16x50	A2 (SS)
⑥	Washer	A2 (SS)
⑦	Nut M16	A2 (SS)
⑧	Ball Valve with Handle	Carbon Steel
⑭	Ball Valve without Handle	Carbon Steel
⑯	Bolt M16x40	A2 (SS)
⑰	Wavy Washer	Stainless Steel
⑱	Flange 6" ANSI 300 PSI	Carbon Steel

Complete with Pressure Relief and Equalizing Valve
Ball Valve - reduced bore diameter (1¼")

Working pressure:	20,7 bar / 300 psi
Operation relief valve:	20 bar +/- 2 bar
Test pressure:	31 bar / 450 psi
Min burst pressure:	62,1 bar / 900 psi
Temperature range:	-30 - +200°C / -20 - +392°F

Surface treatment: Epoxy Coated

Sampling, Vent or Drain Unit in Carbon Steel

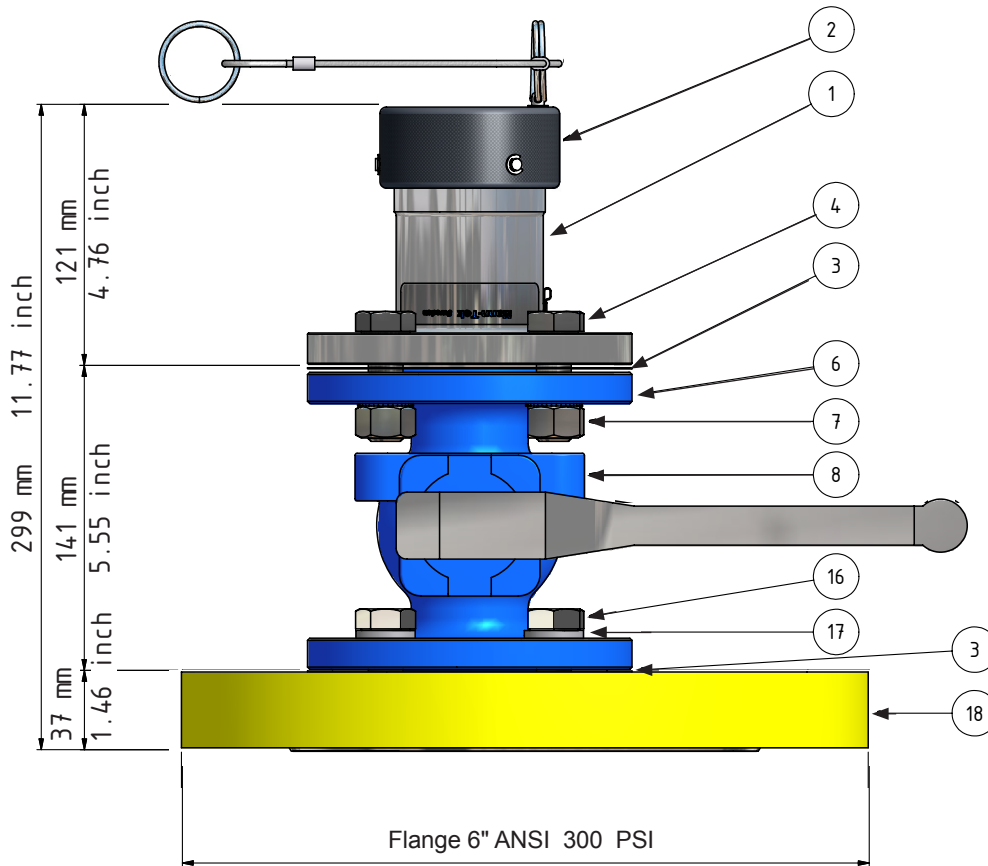

Code No: H227F3301SE

Pos.	Description	Material
①	Tank Unit	Stainless Steel
②	Dustcap	Composite
③	Gasket	Klingerit
④	Bolt M16x50	A2 (SS)
⑥	Washer	A2 (SS)
⑦	Nut M16	A2 (SS)
⑧	Ball Valve with Handle	Carbon Steel
⑭	Ball Valve without Handle	Carbon Steel
⑯	Bolt M16x40	A2 (SS)
⑰	Wavy Washer	Stainless Steel
⑱	Flange 6" ANSI 300 PSI	Carbon Steel

Complete with Pressure Relief and Equalizing Valve

Ball Valve - full bore diameter (40 mm)

Working pressure:	20,7 bar / 300 psi
Operation relief valve:	20 bar +/- 2 bar
Test pressure:	31 bar / 450 psi
Min burst pressure:	62,1 bar / 900 psi
Temperature range:	-30 - +200°C / -20 - +392°F

Surface treatment: Epoxy Coated

Sampling, Vent or Drain Unit in Carbon Steel

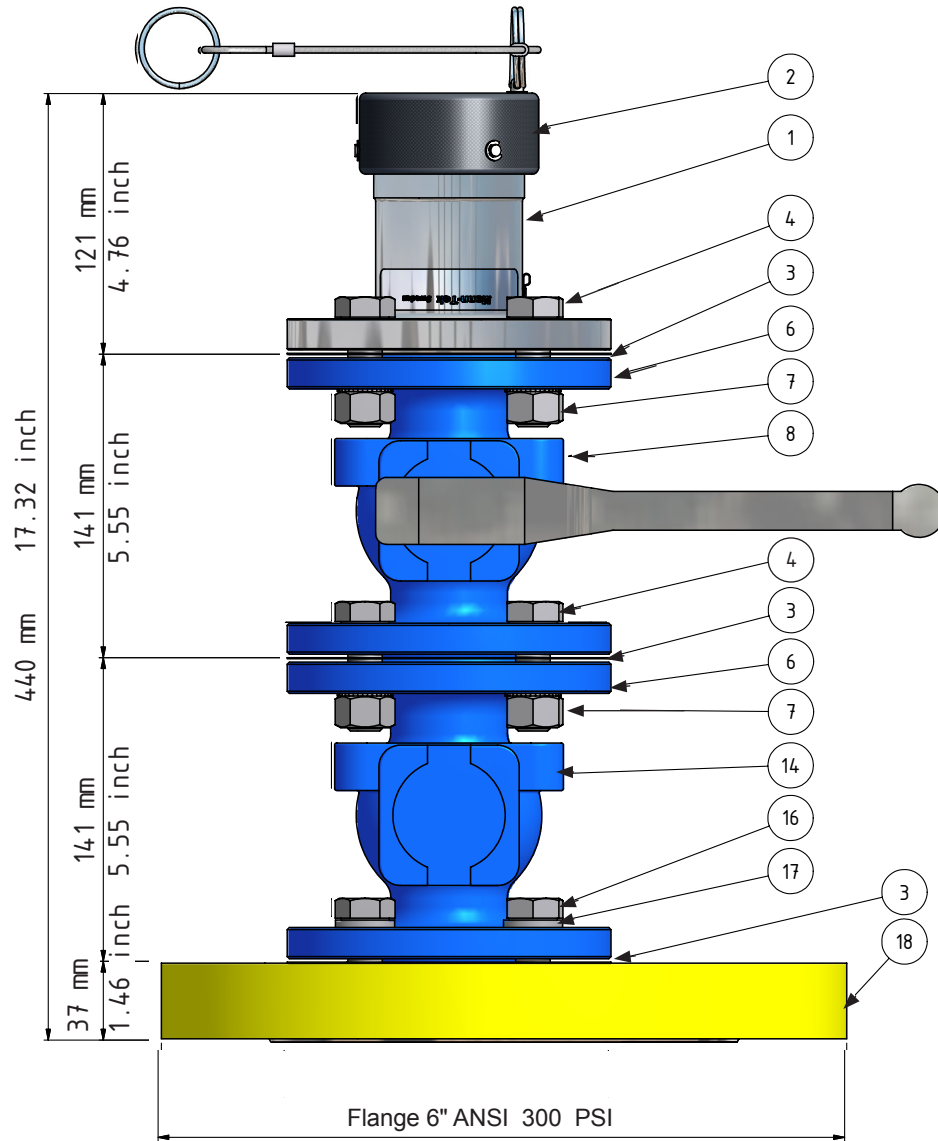

Code No: H227F3301E

Pos.	Description	Material
①	Tank Unit	Stainless Steel
②	Dustcap	Composite
③	Gasket	Klingerit
④	Bolt M16x50	A2 (SS)
⑥	Washer	A2 (SS)
⑦	Nut M16	A2 (SS)
⑧	Ball Valve with Handle	Carbon Steel
⑭	Ball Valve without Handle	Carbon Steel
⑯	Bolt M16x40	A2 (SS)
⑰	Wavy Washer	Stainless Steel
⑱	Flange 6" ANSI 300 PSI	Carbon Steel

Complete with Pressure Relief and Equalizing Valve
Ball Valve - full bore diameter (40 mm)

Working pressure:	20,7 bar / 300 psi
Operation relief valve:	20 bar +/- 2 bar
Test pressure:	31 bar / 450 psi
Min burst pressure:	62,1 bar / 900 psi
Temperature range:	-30 - +200°C / -20 - +392°F

Surface treatment: Epoxy Coated

Sampling, Vent or Drain Unit in Carbon Steel

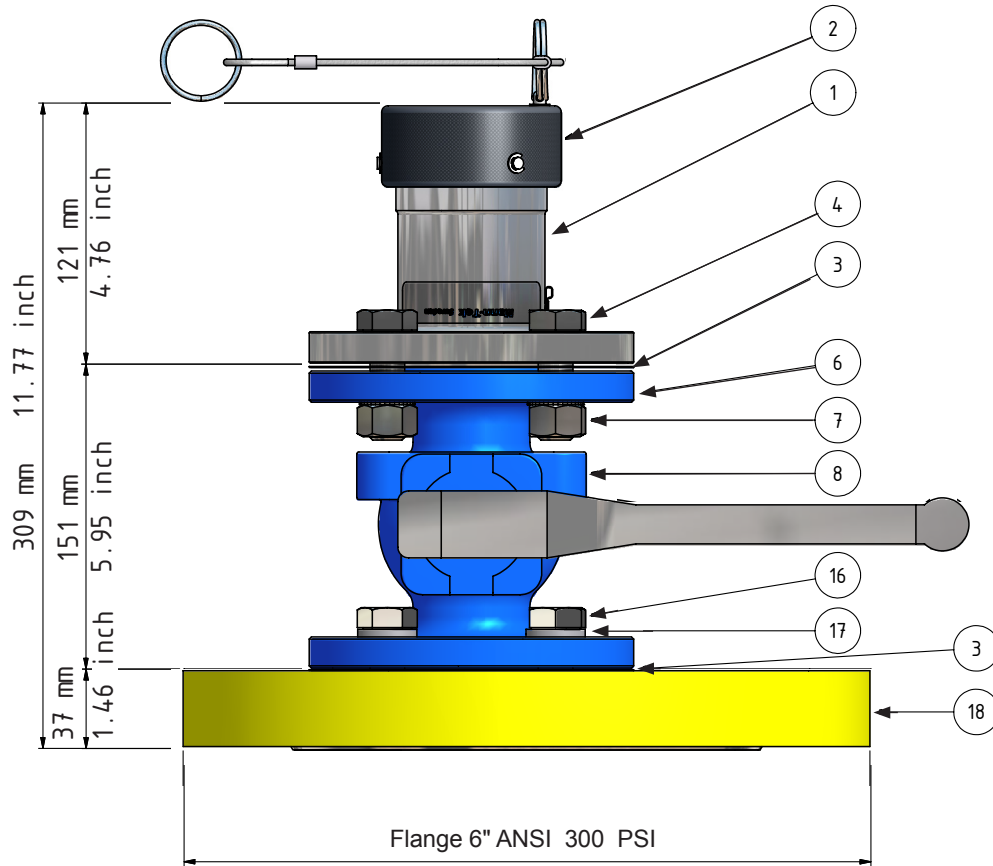

Code No: H230F3301SE

Pos.	Description	Material
①	Tank Unit	Stainless Steel
②	Dustcap	Composite
③	Gasket	Klingerit
④	Bolt M16x50	A2 (SS)
⑥	Washer	A2 (SS)
⑦	Nut M16	A2 (SS)
⑧	Ball Valve with Handle	Carbon Steel
⑭	Ball Valve without Handle	Carbon Steel
⑯	Bolt M16x40	A2 (SS)
⑰	Wavy Washer	Stainless Steel
⑱	Flange 6" ANSI 300 PSI	Carbon Steel

Complete with Pressure Relief and Equalizing Valve

Ball Valve - full bore diameter (50 mm)

Working pressure:	20,7 bar / 300 psi
Operation relief valve:	20 bar +/- 2 bar
Test pressure:	31 bar / 450 psi
Min burst pressure:	62,1 bar / 900 psi
Temperature range:	-30 - +200°C / -20 - +392°F

Surface treatment: Epoxy Coated

Sampling, Vent or Drain Unit in Carbon Steel

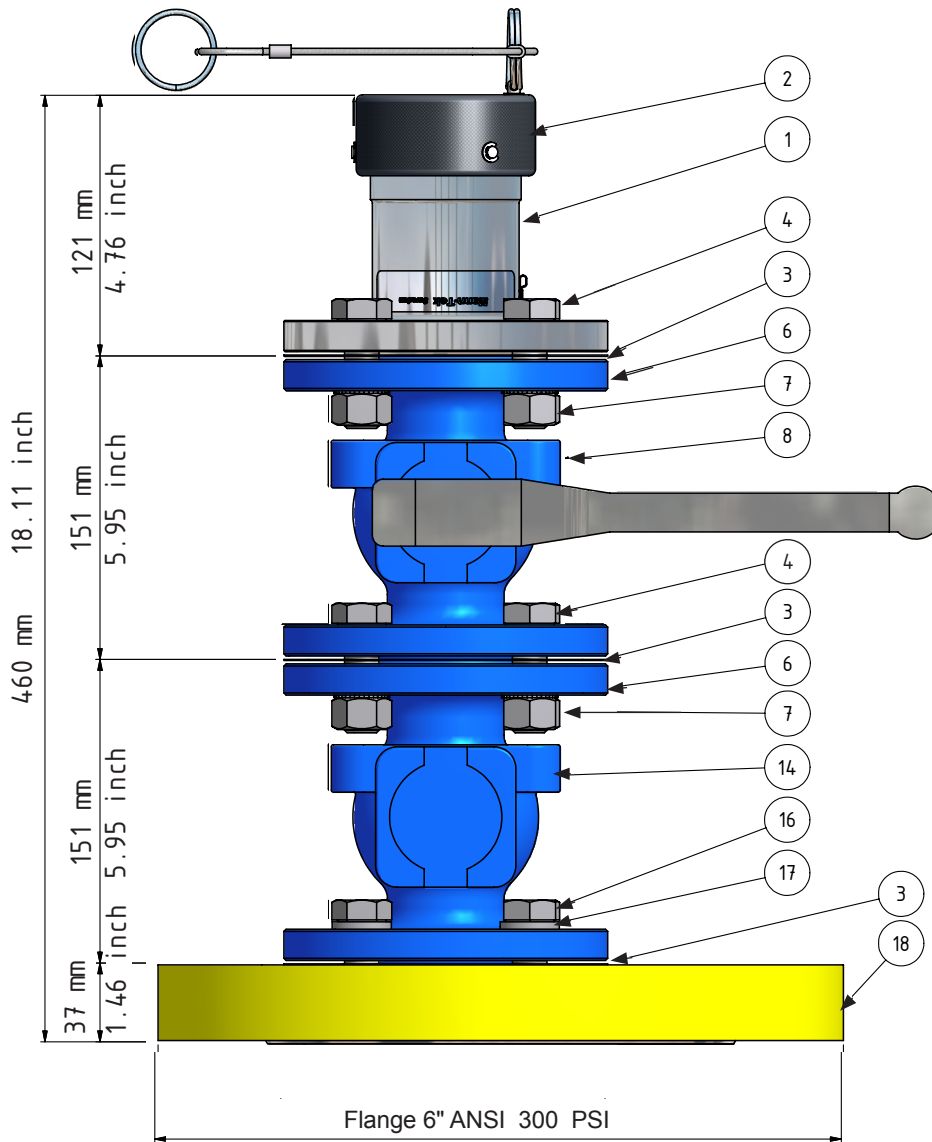

Code No: H230F3301E

Pos.	Description	Material
①	Tank Unit	Stainless Steel
②	Dustcap	Composite
③	Gasket	Klingerit
④	Bolt M16x50	A2 (SS)
⑥	Washer	A2 (SS)
⑦	Nut M16	A2 (SS)
⑧	Ball Valve with Handle	Carbon Steel
⑭	Ball Valve without Handle	Carbon Steel
⑯	Bolt M16x40	A2 (SS)
⑰	Wavy Washer	Stainless Steel
⑱	Flange 6" ANSI 300 PSI	Carbon Steel

Complete with Pressure Relief and Equalizing Valve
Ball Valve - full bore diameter (50 mm)

Working pressure:	20,7 bar / 300 psi
Operation relief valve:	20 bar +/- 2 bar
Test pressure:	31 bar / 450 psi
Min burst pressure:	62,1 bar / 900 psi
Temperature range:	-30 - +200°C / -20 - +392°F

Surface treatment: Epoxy Coated

Sampling, Vent or Drain Unit in Carbon Steel

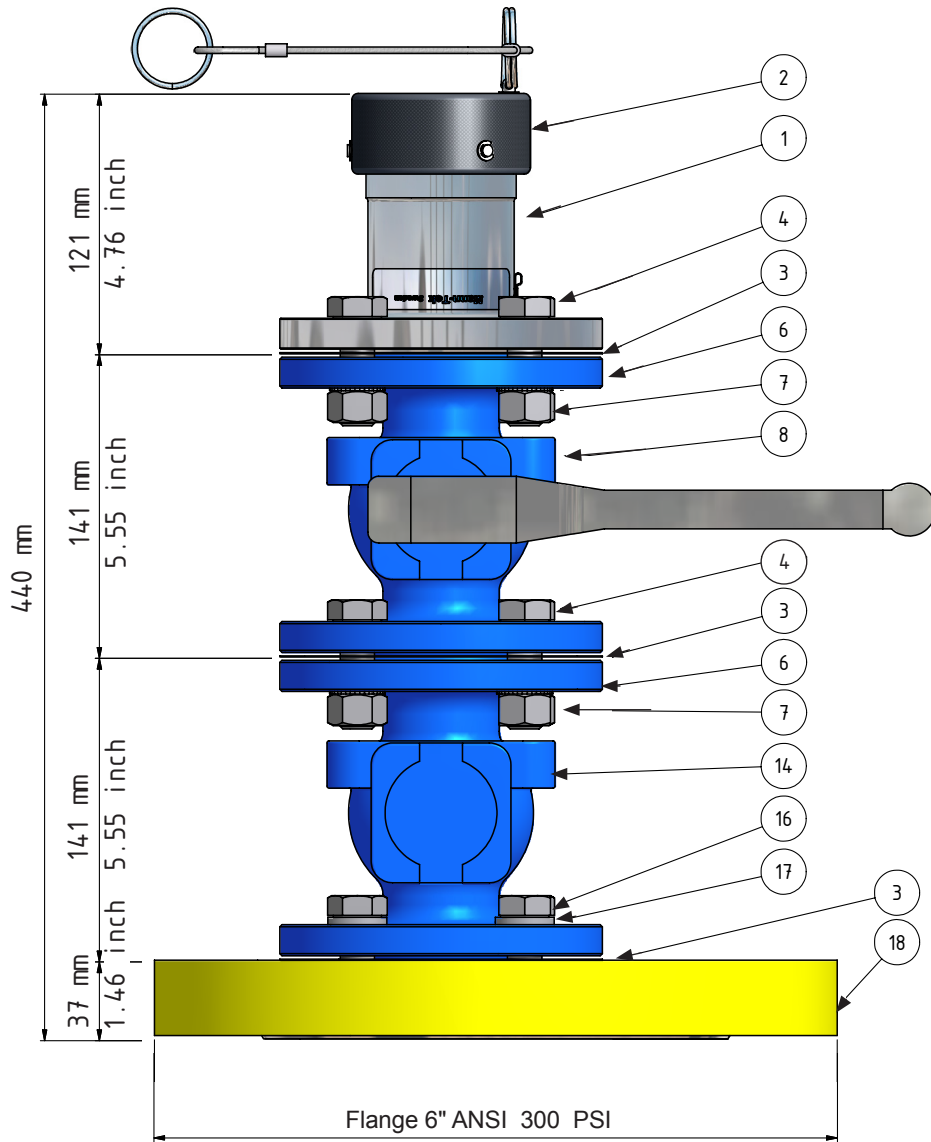

Code No: H257F3301E

Pos.	Description	Material
①	Tank Unit	Stainless Steel
②	Dustcap	Composite
③	Gasket	Klingerit
④	Bolt M16x50	A2 (SS)
⑥	Washer	A2 (SS)
⑦	Nut M16	A2 (SS)
⑧	Ball Valve with Handle	Carbon Steel
⑭	Ball Valve without Handle	Carbon Steel
⑯	Bolt M16x40	A2 (SS)
⑰	Wavy Washer	Stainless Steel
⑱	Flange 6" ANSI 300 PSI	Carbon Steel

Complete with Pressure Relief and Equalizing Valve
Ball Valve - full bore diameter (2")

Working pressure:	20,7 bar / 300 psi
Operation relief valve:	20 bar +/- 2 bar
Test pressure:	31 bar / 450 psi
Min burst pressure:	62,1 bar / 900 psi
Temperature range:	-30 - +200°C / -20 - +392°F

Surface treatment: Epoxy Coated

Tank Unit with standard flange - DN 40

Working pressure: 20,7 bar / 300 psi **Operation relief valve:** 20 bar +/- 2 bar

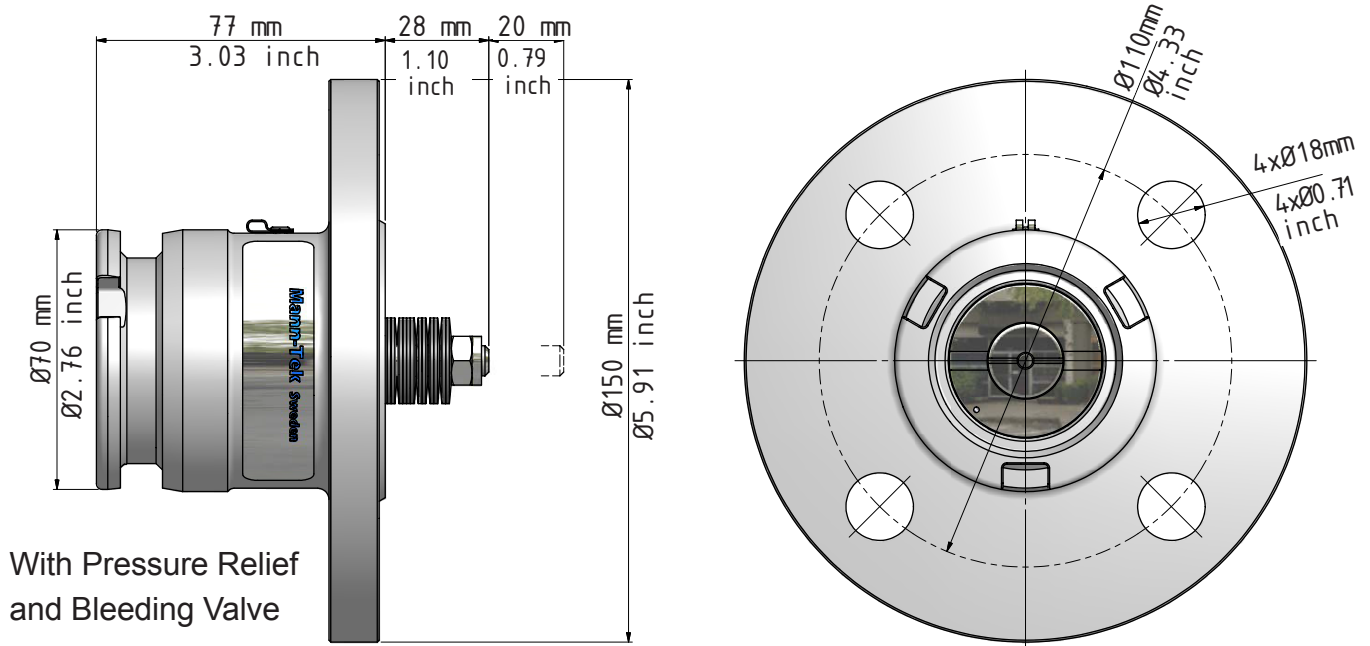

With Pressure Relief and Bleeding Valve

Code nr:	Connection:	Weight:
E227A4401P	DN 40 PN 10/16	2,5 kg / 5,5 lbs

Tank Unit with standard flange - DN 50

Working pressure: 20,7 bar / 300 psi **Operation relief valve:** 20 bar +/- 2 bar

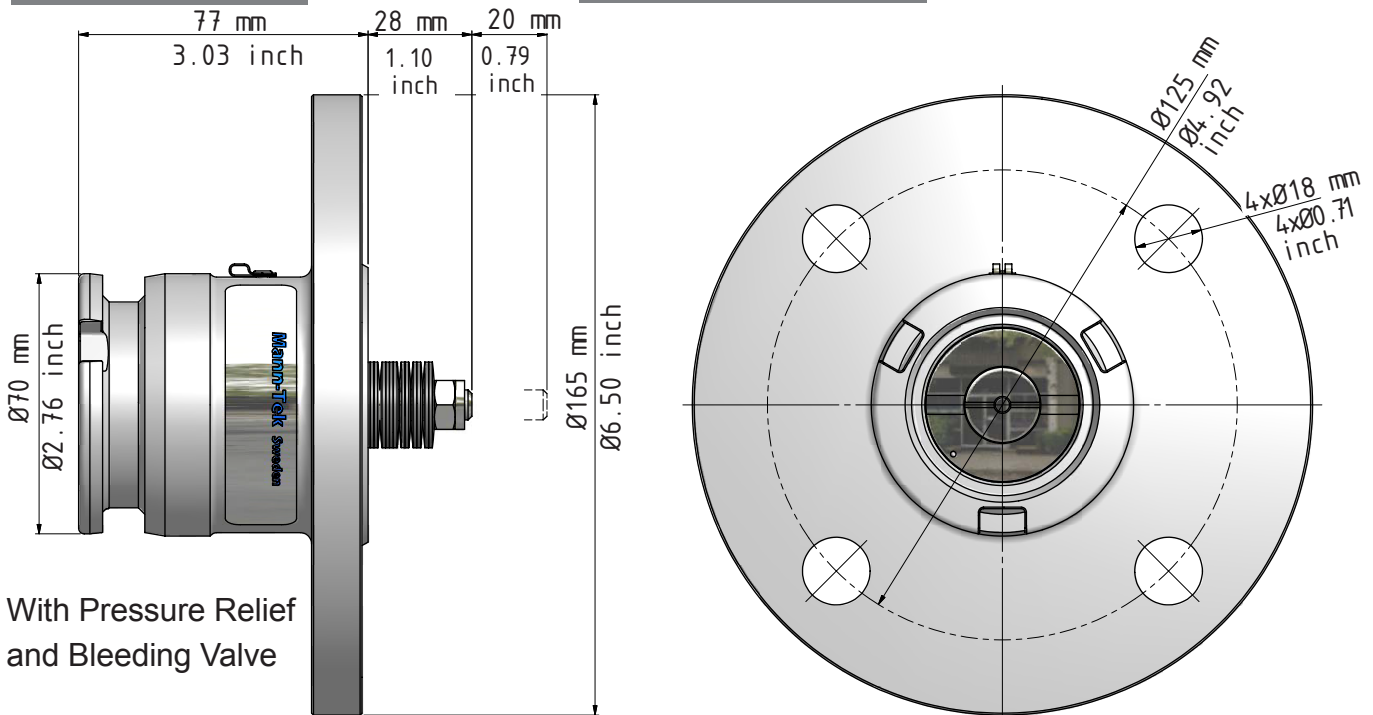

With Pressure Relief and Bleeding Valve

Code nr:	Connection:	Weight:
E230A4401P	DN 50 PN 10/16	2,9 kg / 6,4 lbs

No part of this leaflet may be reproduced in any form or by any means without permission in writing from the publisher.

Tank Unit with standard flange - 1½" ANSI

Working pressure: 20,7 bar / 300 psi

Operation relief valve: 20 bar +/- 2 bar

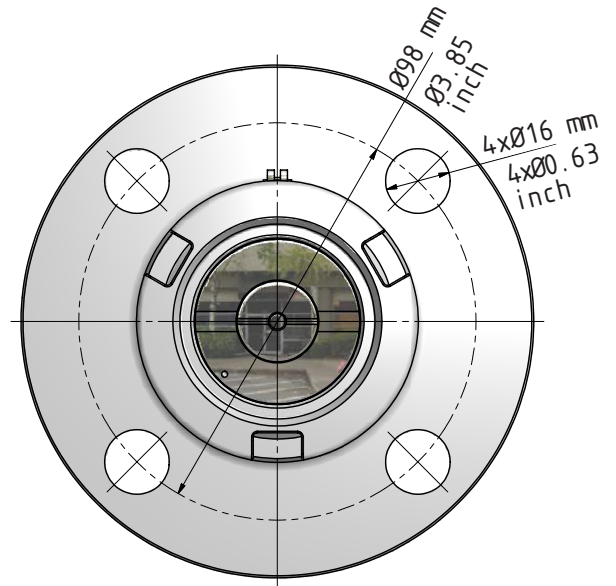
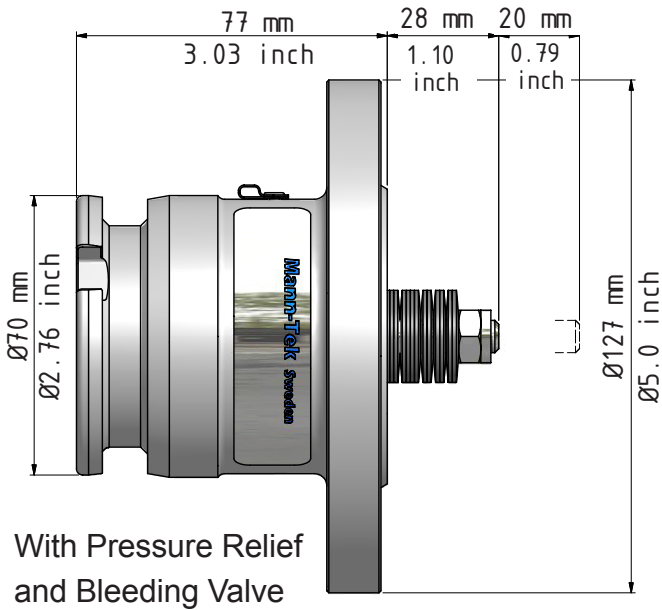

With Pressure Relief and Bleeding Valve

Code nr:

Connection:

Weight:

E255A4401P

1½" ANSI

2,0 kg / 4,4 lbs

Tank Unit with standard flange - 2" ANSI

Working pressure: 20,7 bar / 300 psi

Operation relief valve: 20 bar +/- 2 bar

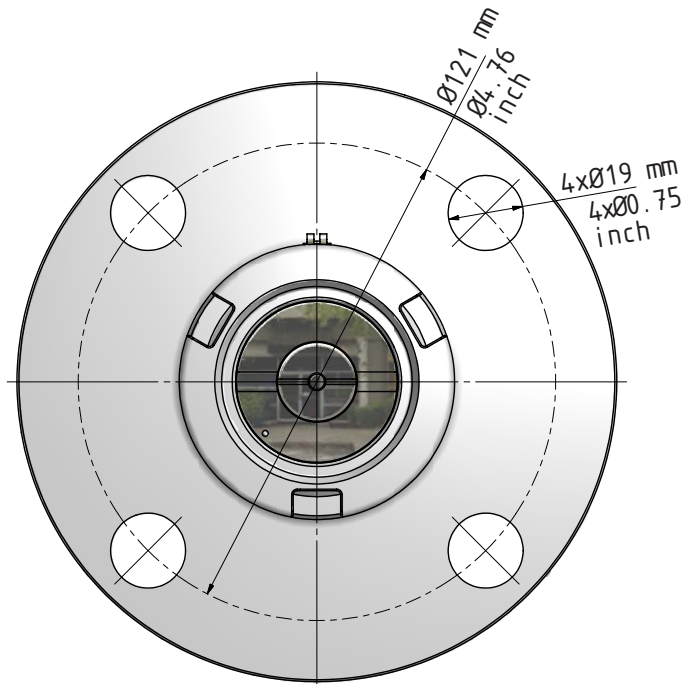
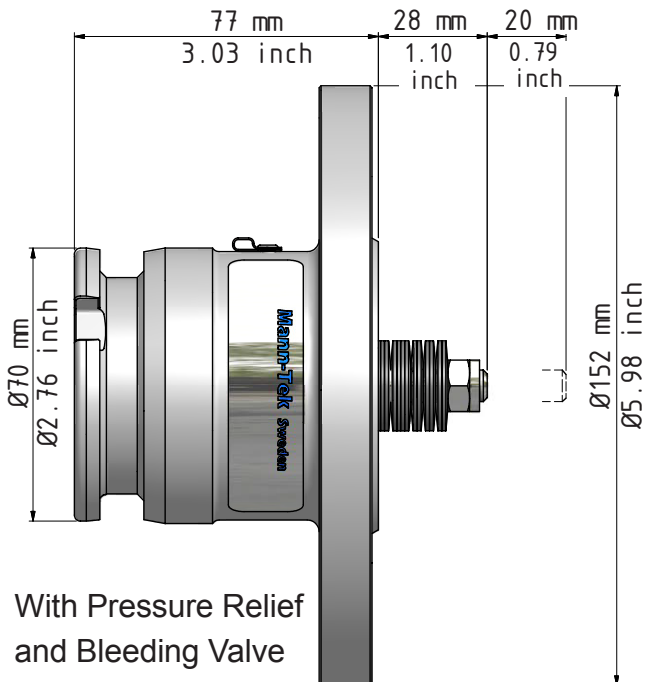

With Pressure Relief and Bleeding Valve

Code nr:

Connection:

Weight:

E257A4401

2" ANSI

2,5 kg / 5,5 lbs

Mounting instruction

When installing Mann Tek equipment to new pipe work, tanks, etc. ensure the system is free from debris that may be transferred through the coupling. Where the hose or loading arm assembly is the primary static dissipation or earth route, the electrical continuity value of the assembly shall be checked to ensure regulatory compliance. Special attention should be paid to the balancing of loading arms. The weight of the coupling plus transfer media should be taken into account at the specification stage. It is usual for loading arm balance settings to account of weight variations due to differences in the full / empty cycle.

The loading arm should be set to balance in the condition present at the time of connection. For example, should the loading arm be empty at the time of connection then it should be balanced in the empty condition.

The Mann-Tek product can be installed directly in the product line and is ready for use after removing the transport protection. The installation is recommended as follows:

- a. Remove the packaging and the flange protection
- b. Check the coupling for damages before mounting.
- c. To prevent damages during mounting a suitable wrench should be used for the intended bolts and nuts.
- d. Ensure that the product line is empty and all valves are close before you connect the coupling into the line.
- e. Set in all bolts first and tighten them by hand. Then increase the tightening torque in 2 steps up to the recommended value in the following table. Proceed every time according to the sequence shown in g.
- f. Tightening torque¹⁾ for bolts:

Metric	
Size	8.8
M8	24 Nm
M10	50 Nm
M12	85 Nm
M16	210 Nm
M20	410 Nm
M22	550 Nm
M24	700 Nm

Inch	
Size	A193 B7
5/16 -18 UNC	16 lbf-ft
3/8 -16 UNC	29 lbf-ft
1/2 -13 UNC	70 lbf-ft
5/8 -11 UNC	139 lbf-ft
3/4 -10 UNC	243 lbf-ft
7/8 -9 UNC	389 lbf-ft
1 -8 UNC	582 lbf-ft

- g. Bolt tightening sequence.

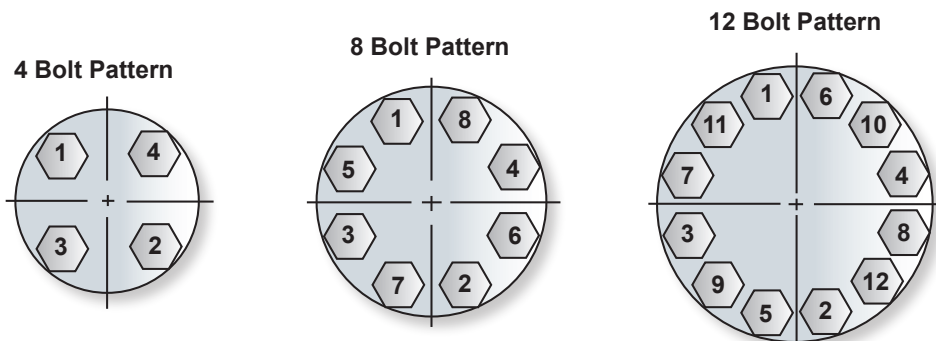

The start-up may take place only when the Mann-Tek product has been mounted as instructed and the necessary function tests and leak tests have been conducted by the approved authorities.

¹⁾ The torque forces recommended bases on a thread friction coefficient $\mu=0,14$ and a standard flat seal according to EN 1514-1

Flange Measurement - 1/2

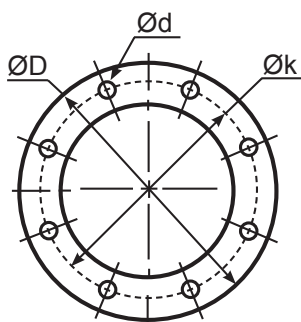

- Ø D = Diameter
- Ø k = Centre diameter
- n = Numer of holes
- Ø d = Hole diameter

EN 1092-1

DN	PN 10				PN 16				PN 25				PN 40			
	ØD	Øk	n	Ød	ØD	Øk	n	Ød	ØD	Øk	n	Ød	ØD	Øk	n	Ød
20	mm	105	75	4	14	105	75	14	105	75	4	14	105	75	4	14
	inch	4.13	2.95		0.55	4.13	2.95	0.55	4.13	2.95		0.55	4.13	2.95		0.55
25	mm	115	85	4	14	115	85	14	115	85	4	14	115	85	4	14
	inch	4.53	3.35		0.55	4.53	3.35	0.55	4.53	3.35		0.55	4.53	3.35		0.55
32	mm	140	100	4	18	140	100	18	140	100	4	18	140	100	4	18
	inch	5.51	3.94		0.71	5.51	3.94	0.71	5.51	3.94		0.71	5.51	3.94		0.71
40	mm	150	110	4	18	150	110	18	150	110	4	18	150	110	4	18
	inch	5.91	4.33		0.71	5.91	4.33	0.71	5.91	4.33		0.71	5.91	4.33		0.71
50	mm	165	125	4	18	165	125	18	165	125	4	18	165	125	4	18
	inch	6.50	4.92		0.71	6.50	4.92	0.71	6.50	4.92		0.71	6.50	4.92		0.71
65	mm	185	145	4	18	185	145	18	185	145	8	18	185	145	8	18
	inch	7.28	5.71		0.71	7.28	5.71	0.71	7.28	5.71		0.71	7.28	5.71		0.71
80	mm	200	160	8	18	200	160	18	200	160	8	18	200	160	8	18
	inch	7.87	6.30		0.71	7.87	6.30	0.71	7.87	6.30		0.71	7.87	6.30		0.71
100	mm	220	180	8	18	220	180	18	235	190	8	22	235	190	8	22
	inch	8.66	7.09		0.71	8.66	7.09	0.71	9.25	7.48		0.87	9.25	7.48		0.87
125	mm	250	210	8	18	250	210	18	270	220	8	26	270	220	8	26
	inch	9.84	8.27		0.71	9.84	8.27	0.71	10.63	8.66		1.02	10.63	8.66		1.02
150	mm	285	240	8	22	285	240	22	300	250	8	26	300	250	8	26
	inch	11.22	9.45		0.87	11.22	9.45	0.87	11.81	9.84		1.02	11.81	9.84		1.02
200	mm	340	295	8	22	340	295	22	360	310	12	26	375	320	12	30
	inch	13.39	11.61		0.87	13.39	11.61	0.87	14.17	12.20		1.02	14.76	12.60		1.18
250	mm	395	355	12	22	405	355	26	425	370	12	30	450	385	12	33
	inch	15.55	13.98		0.87	15.94	13.98	1.02	16.73	14.57		1.18	17.72	15.16		1.30
300	mm	445	400	12	22	460	410	26	485	430	16	30	515	450	16	33
	inch	17.52	15.75		0.87	18.11	16.14	1.02	19.09	16.93		1.18	20.28	17.65		1.30

Flange translation EN 1092 ---- DIN

EN 1092-1	DIN
EN 1092-1 PN 6	DIN 2631
EN 1092-1 PN 10	DIN 2632
EN 1092-1 PN 16	DIN 2633
EN 1092-1 PN 25	DIN 2634
EN 1092-1 PN 40	DIN 2635
EN 1092-1 Type B Raised Face	DIN 2526 Form C
EN 1092-1 Type C Tongue	DIN 2512 Form F
EN 1092-1 Type D Groove	DIN 2512 Form N
EN 1092-1 Type E Spigot	DIN 2513 Form V
EN 1092-1 Type F Recess	DIN 2513 Form R

Flange Measurement - 2/2

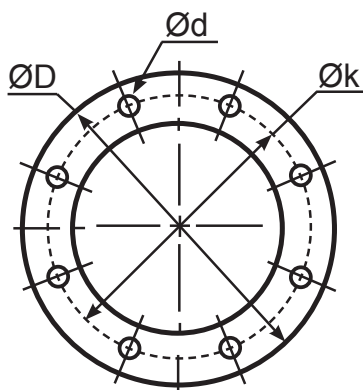

- Ø D = Diameter
- Ø k = Centre diameter
- n = Numer of holes
- Ø d = Hole diameter

ANSI (ASA) B 16,5									
INCH		150 psi			300 psi				
		ØD	Øk	n	Ød	ØD	Øk	n	Ød
3/4"	mm	98,4	69,8	4	15,9	117,5	82,5	4	19
	inch	3 7/8	2 3/4		5/8	4 5/8	3 1/4		3/4
1"	mm	107,7	79,4	4	15,9	123,8	88,9	4	19
	inch	4 1/4	3 1/8		5/8	4 7/8	3 1/2		3/4
1 1/4"	mm	117,5	88,9	4	15,9	133,3	98,4	4	19
	inch	4 5/8	3 1/2		5/8	5 1/4	3 7/8		3/4
1 1/2"	mm	127	98,4	4	15,9	155,6	114,3	4	22,2
	inch	5	3 7/8		5/8	6 1/8	4 1/2		7/8
2"	mm	152,4	120,6	4	19	165,1	127	8	19
	inch	6	4 3/4		3/4	6 1/2	5		3/4
2 1/2"	mm	177,8	139,7	4	19	190,5	149,2	8	22,2
	inch	7	5 1/2		3/4	7 1/2	5 7/8		7/8
3"	mm	190,5	152,4	4	19	209,5	168,3	8	22,2
	inch	7 1/2	6		3/4	8 1/4	6 5/8		7/8
4"	mm	228,5	190,5	8	19	254	200	8	22,2
	inch	9	7 1/2		3/4	10	7 7/8		7/8
5"	mm	254	215,9	8	22,2	279,4	234,9	8	22,2
	inch	10	8 1/2		7/8	11	9 1/4		7/8
6"	mm	279,4	241,3	8	22,2	317,5	269,9	12	22,2
	inch	11	9 1/2		7/8	12 1/2	10 5/8		7/8
8"	mm	342,9	298,4	8	22,2	381	330,2	12	25,4
	inch	13 1/2	11 3/4		7/8	15	13		1
10"	mm	406,4	361,9	12	25,4	444,5	387,3	16	28,6
	inch	16	14 1/4		1	17 1/2	15 1/4		1 1/8
12"	mm	482,6	431,8	12	25,4	520,7	450,8	16	31,7
	inch	19	17		1	20 1/2	17 3/4		1 1/4

TW DIN 28459						
	DN		ØD	Øk	n	Ød
TW1	50	mm	154	130	8	11
		inch	6.06	5.12		0.43
TW1	80	mm	154	130	8	11
		inch	6.06	5.12		0.43
TW3	100	mm	174	150	8	14
		inch	6.85	5.91		0.55
TW5	125	mm	204	176	8	14
		inch	8.03	6.93		0.55
TW7	150	mm	240	210	12	14
		inch	9.45	8.27		0.55

T.T.M.A					
INCH		ØD	Øk	n	Ød
2"	mm	114,3	95,3	6	11,1
	inch	4.50	3.75		0.44
3"	mm	142,9	123,8	8	11,1
	inch	5.63	4.87		0.44
4"	mm	168,3	149,2	8	11,1
	inch	6.63	5.87		0.44
5"	mm	196,9	177,8	12	11,1
	inch	7.75	7.00		0.44
6"	mm	228,6	206,4	12	11,1
	inch	9.00	8.13		0.44
8"	mm	276,2	257,2	16	11,1
	inch	10.87	10.13		0.44

No part of this leaflet may be reproduced in any form or by any means without permission in writing from the publisher.

Product Information



DDCouplings®
Dry Disconnect Coupling.
1" to 8", PN 16 - PN 25. Aluminium, Brass-Gunmetal, Stainless Steel and PEEK. Other materials on request. According to NATO standard STANAG 3756.



DGCouplings®
Dry Gas Coupling.
1" to 8", PN25. Stainless steel. Other materials on request.



DACouplings,
Dry Aviation Coupling.
2½", PN 10. Main body in Aluminium.
Standards: ISO 45, MS 24484, NATO STANAG 3105, British Aerospace Spec. 2C14.



Sampling, Vent or Drain unit
Stainless Steel SS-EN 10 088-1.4404+AT (AISI 316L). Ball Valve in 1.0619 and 1.4301



Full Flow - ballvalves
2" to 4", PN 10, Aluminium.
Ballvalve and 2-way Ballvalve. Made for Petroleum Tank Trucks. Variations of flange connections.



Swivel joints
¾" to 10", PN 10 - PN 25.
Aluminium, Brass-Gunmetal, Stainless Steel.
Other materials on request.
Connection: BSP, NPT. Flanged connection (DIN, ANSI/ASA e.t.c)



SBCouplings, bolt series
Industrial and Marine Safety Break-away, breaking bolts,
Aluminium, Brass, Stainless Steel, 1" to 12", female/male threads and with flanges, with breaking bolts.
Safety Break-away, cable release
Stainless Steel, PN10 / PN 25. 2" to 4", female threads. 6" to 12", flanged connection

Business Segment Information



Offshore & Marine



Gas (LPG)



Rail tankers



Chemical industry



Tank trucks



Military



Container



Cryogenic Couplings

Company Information

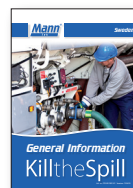

General Information about Mann Tek, products and Business Segments



Quality, Health, Safety and Environment Policy. Quality Approvals, Product Approvals and Declaration of Conformity

Service



Service instructions and operation manuals

Your distributor

Your distributor:

Contact Mann Tek for your local distributor

Phone: +46 501 39 32 00
Fax: +46 501 39 32 09
Email: sales@manntek.se
Web site: www.manntek.se

Address: Mann Teknik AB
Strandvägen 16
SE-542 31 Mariestad
Sweden



Mann-Tek is a certified ISO9001-company.