

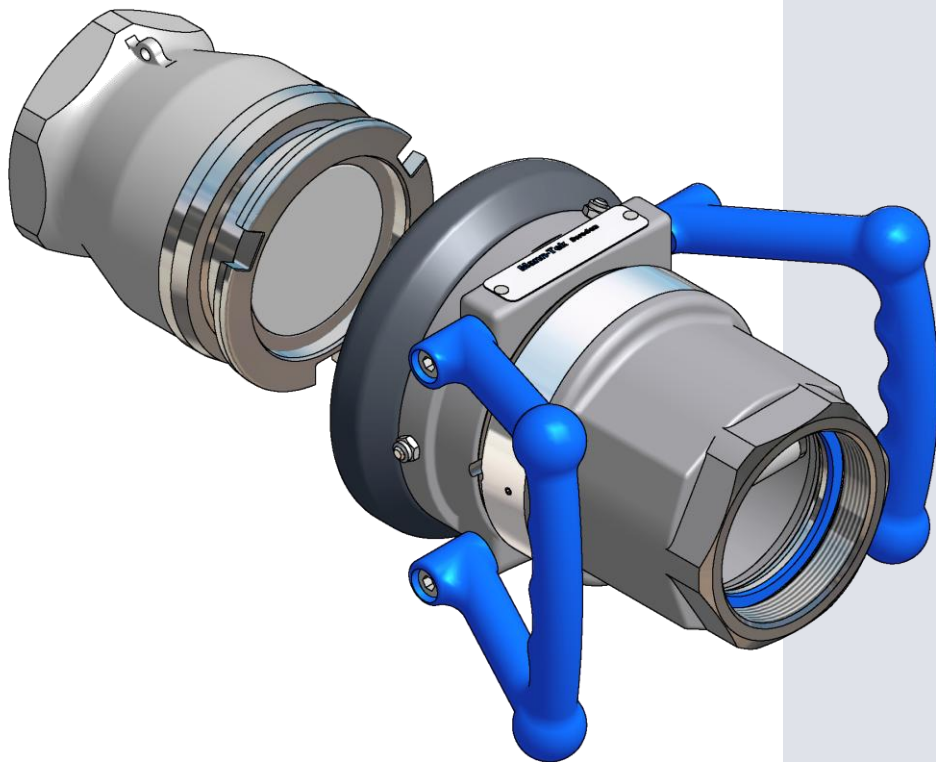

DDCouplings[®]

Dry Disconnect Couplings



Operating Manual

Subject to design changes

Art. nr: PR-050123-0121 Version: 100308



Foreword

This operating manual applies to the person or persons using the Dry Disconnect couplings.

It is very important to read and understand this operation manual before use of this coupling. Become familiar with the unit's operation, applications and limitations. Be particularly aware of its specific hazards. Store this manual in a clean area and always at a readily available location. Additional copies at no charge can be obtained through written requests.

IMPORTANT!! READ THE COMPLETE DOCUMENTATION

The base for this manual follows the EC-Directive:

Pressure Equipment Directive
97/23/EG of the 29th of May 1997

- Do not make modifications that are not authorized by the manufacturer.
- Read and respect all warnings and instructions provided to you.
- Use only original Mann Technik spare parts for maintenance.

Summary of revisions

Date of change	Description
2004-02-09	New pressure ratings, Storage
2004-02-20	Copyright remark
2008-10-29	New front page layout
2010-03-08	General review

Table of Content

FOREWORD.....	2
SUMMARY OF REVISIONS.....	2
TABLE OF CONTENT.....	3
1 INTRODUCTION.....	4
1.1 Intended use.....	4
1.2 Product specification.....	5
1.3 Identification plate e.g. for DDC 3"-3"BSP.....	5
1.4 Scope of delivery.....	5
2 GENERAL SAFETY RULES.....	6
2.1 Safety Instructions.....	6
3 TRANSPORT AND STORAGE.....	7
3.1 Delivery Check.....	7
3.2 Complaints / Return of goods.....	7
3.3 Returning Used Product.....	7
3.4 Sample of Certificate of Decontamination.....	8
3.5 Storage.....	8
4 INSTALLATION.....	9
4.1 Initial Operation.....	9
4.2 Installation.....	9
5 OPERATION.....	12
5.1 General notes.....	12
5.2 Making connection/disconnection.....	12
5.3 Daily visual inspection.....	13
5.4 Cleaning.....	13
5.5 Disassembly.....	13
5.6 Improper use.....	14
5.7 Maintenance / repair.....	14
5.8 Miscellaneous.....	14
6 MAINTENANCE AND REPAIR.....	14
6.1 General information.....	14
6.2 Maintenance and service instruction.....	14
6.3 Pressure and tightness test.....	15
7 APPLICABLE DOCUMENTS.....	16
7.1 Declaration of Conformity.....	16

1 INTRODUCTION

1.1 INTENDED USE

Dry Disconnect Couplings (DDCs) are designed for use wherever it is necessary to connect and disconnect hoses and pipelines under moderate pressure, quickly and without spillage. They are designed primarily for use with dangerous goods where reliability and safety are of prime concern.

All Mann Tek products are designed for trouble free operation in a wide range of applications and operating conditions. Reliable and safe operation is dependent upon the correct installation and handling of the equipment. Regular and appropriate maintenance is essential to ensure both safety and reliability over the life of the equipment. Take care that the product is only used inside the limits of the following product specification.

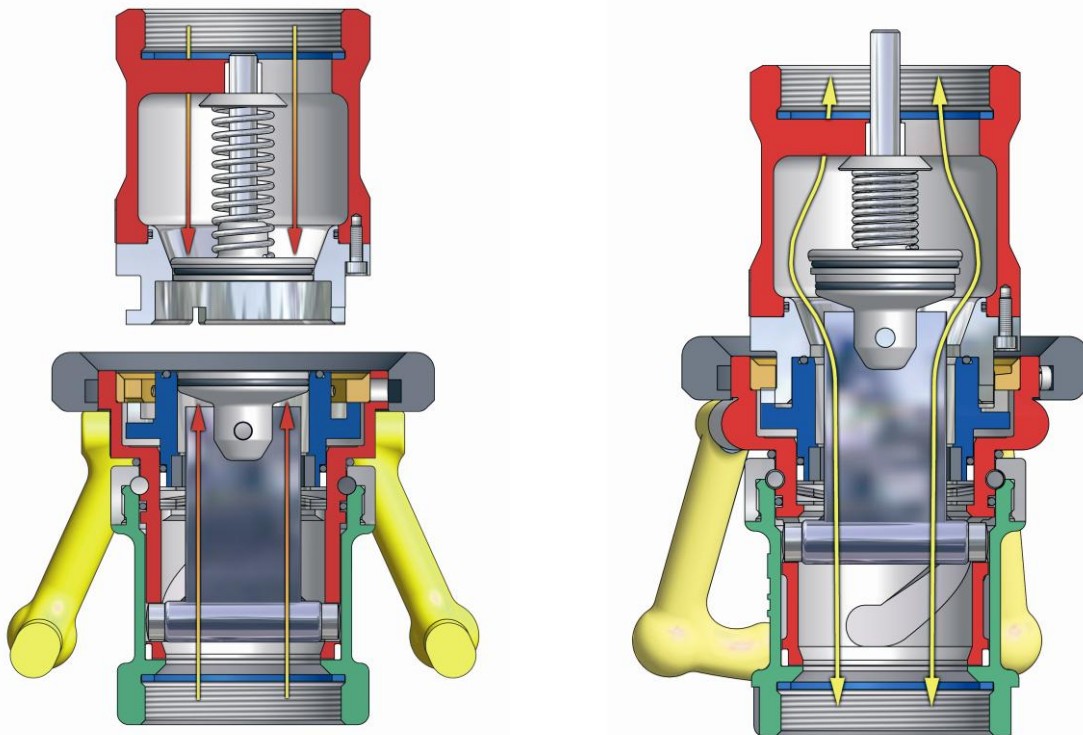

Operation is single action (see chapter 5.2), using a straight forward turning motion to connect the couplings and open a flow path. An initial push and turn action on the hose unit causes engagement with the tank unit, thus locking and sealing the two units together. Further rotation causes the internal valves to open, thereby allowing flow with minimum pressure drop.

The connection and valve mechanism is interlocked such that fully engaging and sealing the hose unit on its matching tank unit can only open the valve. On disconnection the valve fully close before the coupling separate and spillage therefore is negligible.

Operating Manual

Dry Disconnect Couplings



1.2 PRODUCT SPECIFICATION

Product name:	Dry Disconnect Coupling
Sizes:	¾", 1", 2", 2½", 3", 4" and 6"
Thread Connection:	BSP-Thread ISO228, NPT-Thread ANSI B1.20.1 BSPT-Thread EN10226, ACME, S60x6
Flange Connection:	Flange EN 1092, ANSI B16.5, DIN28459, T.T.M.A.
Other Connections	MIL-C-10387J, DIN 11864, DIN32676, ISO2852
Material (casting):	EN 10213 – 1.4408/1.4409+AT ASTM A351 – CF-3M or CF-8M EN 1982 – CC491K EN 1706 – AC-42000/42100-T6
Material (machined):	EN 10272 – 1.4401/1.4404+AT ASTM A479 – S31603 (316L) EN 12164 – CW614N EN 755-2 – EN AC-6026/6262-T6
Temperature range:	-25°C to +80°C (outside this range between -54°C and +250°C, ask for confirmation!)

Working pressure and classification according to PED 97/23/EC:

	<i>Alu</i>	<i>Gunmetal Brass</i>	<i>SS</i>	<i>PEEK PVDF</i>
¾" (DN 20)	PN 16*	PN 16*	PN 25*	PN 6
1" (DN 25)	PN 16*	PN 16*	PN 25*	PN 6
1½" (DN 40)	PN 16 cat.1	PN 16 cat.1	PN 25 cat.1	PN 6
2" (DN 50)	PN 16 cat.1	PN 16 cat.1	PN 25 cat.2	PN 6
2½" (DN 65)	PN 10 cat.1	PN 10 cat.1	PN 25 cat.2	PN 6
3" (DN 80)	PN 10 cat.1	PN 10 cat.1	PN 25 cat.2	PN 6
4" (DN 100)	PN 10 cat.1	PN 10 cat.1	PN 25 cat.2	PN 6
6" (DN 150)	PN 10 cat.1	PN 10 cat.1	PN 16 cat.2	

* 1" and smaller: Art.3 par.3 "good manufacturing practice"; CE marking acc. to ATEX but not PED

1.3 IDENTIFICATION PLATE e.g. for DDC 3"-3"BSP

	Hose unit (Coupler)	Tank unit (Adapter)
Article no:	S414B1101B*	T414B1101B*
Size:	3" – 3" BSP	3" – 3" BSP
Working Pressure PS:	10 bar	10 bar
Material:	Aluminium	Aluminium
Seal:	FPM (Viton®)	FPM (Viton®)

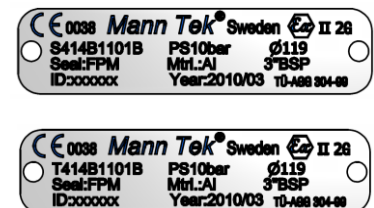

*For key of article no. please ask for explanation list.

1.4 SCOPE OF DELIVERY

1 pcs	S414B1101B	DDCoupling 3" Hose unit with 3" BSP thread and/or
1 pcs	T414B1101B	DDCoupling 3" Tank unit with 3" BSP thread

In case of flange connection gaskets and bolts to mount the coupling into the application is not part of the delivery. For NPT thread use PTFE tape for sealing (see chapter 4.2).

2 GENERAL SAFETY RULES

Before you install any Mann Tek equipment it is essential to check that the material and performance specifications are acceptable for your specific application. The pressure ratings and primary materials of the construction are clearly indicated on the identification plate of each Mann Tek product. A drawing showing the materials of construction relating to each individual component is available upon request. The technical department at Mann Teknik AB is always happy to provide guidance on material suitability. Our data is taken from published chemical resistance information as well as our own application experiences. Specification checks should always be carried out before the product is supplied, but if unsure, ask! Especially if you are using the products outside the specified temperature range, ask for confirmation regarding your application.

Do not assume that a Mann Tek product supplied for one specific application automatically will be suitable for other similar applications. Many variables affect the performance of materials. If you wish to use a Mann Tek product for a different application than the one originally specified, check with Mann Teknik AB to ensure compatibility before installation. Please remember, the application details should include all media transferred through the coupling. Not just the primary transferred media. As with all equipment, a check should be made to ensure that the installation fulfils the requirements of applicable prevailing industry, local, national and international standards. Particular attention should be paid to pressure ratings, safety factors and the position of upstream and downstream affiliated closures.

2.1 SAFETY INSTRUCTIONS



Proper seal and wetted metal parts material selection is critical for safe operation. To assure maximum life for the service intended, use only those materials, sealing and lubricant compatible with the fluids being handled. Please note material being supplied and make certain that it is suited for the intended service. This is important in the food processing industry.



The Dry Disconnect Coupling assembly does not eliminate possible exposure to hazardous substances. Likewise, some product residue may appear on the disc faces. The conditions of handling and use are beyond our control, and we make no guarantee, and assume not liability for damages or injuries related to the use of this coupling assembly. It is the responsibility of the user to comply with all applicable federal, state, and local laws and regulations.



Piping systems behind the tank unit should always be open before connecting. Do not use external tools to make a connection. It is impossible to connect against trapped liquid. Check if all valves in the pipeline are open.



Do not handle o-ring seals if their material appears charred, gummy or sticky. Use tweezers; wear gloves and protective goggles in appropriate material, consult the material safety data sheet (MSDS) of your product. Do not touch adjacent parts with unprotected hands.



Piping systems must always be depressurised and drained before attempting disassembly and removal of any Mann Teknik AB products.



Authorized and qualified personnel must carry out all assembly and maintenance operations. The installation must be equipped with suitable controls that prevent an increase of pressure beyond the maximum allowed limit (this is the responsibility of the installer/user).

Failure to do so could result in serious personal injury, property damage, leakage or unexpected separation.

For a safe operation, read also the installation and operating instructions in this manual (see chapter 4 and 5) and ask for our service instructions.

3 TRANSPORT AND STORAGE

The product may only be transported or stored when absolutely clean. Suitable sealing must be used for the openings to ensure no damage occurs to the surfaces/sealed areas. The seals may only be removed by trained personnel. The storage location must guarantee adequate protection from corrosion or extreme temperatures.

3.1 DELIVERY CHECK

- Check for any transportation damage. If so report this immediately to the forwarder.
- Check that the products and quantities are in accordance with the delivery note.

3.2 COMPLAINTS / RETURN OF GOODS

- If returning goods please contact Mann Teknik AB to receive a Complaint Report form.
- Complete the form with as much details as possible.
- Return the goods with the Complaint Report attached on the outside of the package!

3.3 RETURNING USED PRODUCT

- If returning **used** goods please contact Mann Teknik AB to receive a Complaint Report form.
- Complete the form with as much details as possible.
- Fill in the Certificate of Decontamination. For a sample see chapter 3.4
- Return the goods with the Complaint Report **and** the Certificate of Decontamination!

3.4 SAMPLE OF CERTIFICATE OF DECONTAMINATION

Make a copy of this page, fill in the required information and send it back together with the goods.

REPAIR SERVICE		
To comply with Health & Safety Regulations, all returned valves must be accompanied by a Certificate of Cleanliness and a Data Sheet for the last product carried (even the cleaner).		
CERTIFICATE OF DECONTAMINATION		
We certify that the following couplings/valves have been cleaned prior to despatch and are free of any harmful substances:		
Quantity:	_____	
Part no:	_____	
Serial No:	_____	
Quantity:	_____	
Part no:	_____	
Serial No:	_____	
Quantity:	_____	
Part no:	_____	
Serial No:	_____	
	YES	NO
Free of all liquid	_____	_____
Air blown	_____	_____
Couplings/Valve dismantled	_____	_____
Data sheet of last product attached	_____	_____
The last known product the coupling/valve was in contact with:		

Media CAS Number:	_____	

Company Name/Address (Stamp):	Signature of Supervisor:	

3.5 STORAGE

Store coupling in a dry, dust free, dark place, in ambient temperature.

4 INSTALLATION

4.1 INITIAL OPERATION

The correct installation of all Mann Tek products is essential to ensure safe and satisfactory operation. Checks should be made to ensure that the fitting of Mann Tek products does not interfere with the correct operation of affiliated equipment (i.e. isolation valve, excess flow valves, etc). Before securing the flange or thread connection to mating equipment (i.e. hose, loading arm and storage tank) ensures that no foreign objects, dirt, grit, etc. are present in the coupling.

All flange and thread connections should be made without imparting excessive strain to the equipment and pressure checked at least to 1.5 times the maximum application working pressure prior to use. All gaskets and sealing materials used to make the permanent connection should be of suitable material and able to operate at least up to the maximum parameters of the Mann Tek equipment.

Each Mann Tek product is designed to take reasonable axial loads associated with good handling practice but is not designed to accept continuous excessive load values associated with maladjustment or poor installation. Continuous excessive strain will equate to increased component wear and possibly premature failure if not corrected.

When Mann Tek equipment is used with hoses, attention should be paid to hose length to ensure correct handling characteristics. The hose assembly should be designed such that the minimum hose length is supported by the coupling or the operator. Hoses should be of sufficient length to ensure operation well within the stipulated hose minimum bend radius up to the maximum operation envelope. If the flow velocity exceeds 5.25 m/s additional measures are necessary due to static electricity. This could be hoses with increased conductivity, charge inhibiting additives, earth bonding.

Once all the above elements are satisfactory, a function check should be carried out to prove the system. The hose unit or coupler should connect and disconnect without physical interference or difficulty. Please remember that the higher the static pressure, the greater the effort to make a connection. The Mann Tek technical department is happy to advice on this subject at the specification stage.

4.2 INSTALLATION

When installing Mann Tek equipment to new pipe work, tanks, etc. ensure the system is free from debris that may be transferred through the coupling. Where the hose or loading arm assembly is the primary static dissipation or earth route, the electrical continuity value of the assembly shall be checked to ensure regulatory compliance. Special attention should be paid to the balancing of loading arms. The weight of the coupling plus transfer media should be taken into account at the specification stage. It is usual for loading arm balance settings to account of weight variations due to differences in the full / empty cycle.

The loading arm should be set to balance in the condition present at the time of connection. For example, should the loading arm be empty at the time of connection then it should be balanced in the empty condition.

The Mann Tek product can be installed directly in the product line and is ready for use after removing the transport protection. The installation is as follows:

- a. Remove the packaging and the thread/flange protection.
- b. Check the coupling for damages before mounting.
- c. To prevent damages during mounting a suitable wrench should be used for the intended nut flats on the coupling (threaded connection) or the bolts (flanged connection).
- d. Ensure that the product line is empty and all valves are closed before you connect the coupling into the line.

Flange connection

- a. Table 6: Tightening torque¹ for bolts:

Metric		Inch	
Size	8.8	Size	A193 B7
M8	24 Nm	5/16 -18 UNC	16 lbf-ft
M10	50 Nm	3/8 -16 UNC	29 lbf-ft
M12	85 Nm	1/2 -13 UNC	70 lbf-ft
M16	210 Nm	5/8 -11 UNC	139 lbf-ft
M20	410 Nm	3/4 -10 UNC	243 lbf-ft
M22	550 Nm	7/8 -9 UNC	389 lbf-ft
M24	700 Nm	1 -8 UNC	582 lbf-ft

- e. Bolt tightening sequence.

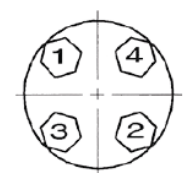

4 Bolt Pattern

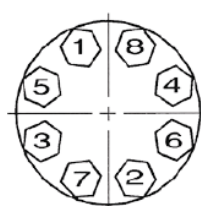

8 Bolt Pattern

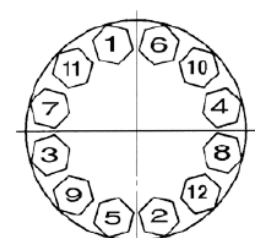

12 Bolt Pattern

¹ The torque forces recommended bases on a thread friction coefficient $\mu=0,16$ at 70% of the preload force

NPT thread connection

Sealing NPT threads can be an exasperating experience if certain techniques are not followed.

The following tips will help alleviate many common problems in thread sealing:

- f. Always use some type of sealant (tape or paste) and apply sealant to male thread only. If using a hydraulic sealant, allow sufficient curing time before system is pressurized.
- g. When using tape sealant, wrap the threads in a clockwise motion starting at the first thread and, as layers are applied, work towards the imperfect (vanishing) thread. If the system that the connection being made to cannot tolerate foreign matter (i.e. air systems), leave the first thread exposed and apply the tape sealant as outlined above.
- h. When using paste sealant, apply to threads with a brush, using the brush to work the sealant into the threads. Apply enough sealant to fill in all the threads all the way around.
- i. When connecting one stainless steel part to another stainless steel part that will require future disassembly, use a thread sealant that is designed for stainless steel. This stainless steel thread sealant is also useful when connection aluminium to aluminium that needs to be disconnected in the future. These two materials gall easily, and if the correct sealant is not used, it can be next to impossible to disassemble.
- j. When connecting parts made of dissimilar metals (i.e. steel and aluminium), standard tape or paste sealant performs satisfactory.
- k. For sizes 2" and below, tape or paste performs satisfactory. When using thread tape, four wraps (covering all necessary threads) are usually sufficient.
- l. For sizes 2 1/2" and above, thread paste is recommended. If thread tape is used, eight wraps (covering all necessary threads) are usually sufficient. Apply more wraps if necessary.
- m. Over-tightening threads can be just as detrimental as insufficient tightening. For sizes 2" and below, hand tighten the components and, with a wrench, tighten 3 full turns. For sizes 2 1/2" and above, hand tighten the components and, with a wrench, tighten 2 full turns.
- n. For stubborn to seal threads, apply a normal coating of thread paste followed by a normal layer of thread tape.
- o. For extremely stubborn to seal threads, apply a normal coating of thread paste followed by a single layer of gauze bandage followed by a single layer of gauze bandage followed by a normal layer of thread tape.



When this procedure is done, the connection becomes permanent. Extreme measures will be necessary to disconnect these components. All other measures to deal the threads should be explored prior to use of this technique.

The start-up may take place only when the Mann Tek product has been mounted as instructed and the necessary function tests and leak tests have been conducted by the approved authorities (see chapter 7).

5 OPERATION

5.1 GENERAL NOTES

Operators are obliged to provide qualified and trained personnel familiar with the handling of supply pipes, safety couplings, any fluid being pumped as well as its danger potential. Such staff must also be familiar with the applicable safety regulations and the regulations of the employer's liability association. Notice also our safety instructions (see chapter 2.1).



When making the connection, make sure that all relevant isolation valves connected in the hose unit application are closed. Also check that no pumping pressure is present at the hose unit. Make sure that all isolation valves behind the tank unit in the pipe work are fully open.

5.2 MAKING CONNECTION/DISCONNECTION

Lift the hose unit and hose into position to start the connection. Take care to support the hose end assembly so as to present the hose unit to the tank unit in the correct orientation. It is important to ensure the hose unit is not supporting the full weight of the hose assembly during the connection process. Loading should be balanced to a neutral condition in the connection phase. Once connected, the hose unit is secure to the tank unit and able to accommodate all reasonable axial strain. The handles have no operating purpose other than providing handling assistance.

When correctly supported, the hose unit should slide easily over the tank unit. The three tappets on the tank unit engage in the three slots in any one of three positions at 120 degree centre. Rotate the hose unit clockwise about 100 degrees whilst gently pushing towards the tank unit. At the start of rotation you will feel some resistance. The level of resistance is dependent upon the static line and tank pressure. The higher the pressure the greater is the effort necessary to connect the coupling. At the completion of the 100 degree turn you will feel a definite stop. Do not attempt to rotate the unit further. Further rotation does not tighten the connection or open the valves more, it only causes unnecessary damage. The hose unit valve is now open and the loading process can start.

The sequence of isolation valve and/or pump operation should be taken from your operating procedures; however it is preferable for the vehicle isolation valve to be the last valve opening in the sequence. This reduces the possible surge effect on the coupling seals often associated with automatically actuated valve systems.

The disconnection procedure is similar to the connection procedure but in reverse. Before any attempt is made to disconnect the coupling, all isolation valves should be closed and where possible, the pumps be switched off. Where a common pumping system is in use, all flow through the coupling shall be stopped

using the isolation valves and not the coupling. Closing the vehicle isolation valve first is preferred according to reasons in the first paragraph so long as this is compatible with your standard operating procedures.

Whilst supporting the hose unit assembly, turn the hose unit anti-clockwise approximately 100 degrees. You may feel a slight “pop off” effect at the end of the rotation travel when transferring liquids with an elevated vapour pressure. This is normal. Do not attempt to rotate the hose unit further. This will not further loosen the connection or secure the seal, it only causes unnecessary damage.

The hose assembly should be stowed in a manner so as to avoid physical damage. Do not drop the hose end assembly or stow on the floor. The dust plug provided should always be fitted. Ensure the tank unit cap (if fitted) is replaced and secured.

5.3 DAILY VISUAL INSPECTION

All couplings should be briefly inspected at the start of each day's operation.

Inspect the coupling surface for cleanliness and corrosion. Check for dirt and any obvious physical damage (such as impacts, etc.).

Inspect the O-ring in the hose unit connection for serviceability and correct seating in the groove.

Inspect the hose unit swivel for free rotation.

Inspect the tank- and hose unit for faultlessness and external signs of seizure.

On the first operation, check for leakage and smooth operation.

5.4 CLEANING

Check the seal of the connections before every cleaning. In case the coupling is used for materials that harden, stick, etc., the coupling has to be cleaned of residues after every use. Before dismantling, the coupling always has to be cleaned with a suitable cleaning agent (regardless of the product carried).

5.5 DISASSEMBLY

When the DDCoupling should go into service there is a danger that the fluid will spurt out. Special protective measures such as personal protection equipment must therefore be adopted. Always ensure that the system is cleaned in the proper manner. After cleaning, remove any residue from the cleaning agent.

How to disassemble:



Wear suitable personal safety equipment.

Make sure that the coupling is depressurized and empty.

Clean coupling before disassembly (use cleaning agent suitable for the pumped fluid).

Unscrew coupling (threaded connection) or bolts (flanged connection) with a fitting wrench.

5.6 IMPROPER USE

The equipment should never be used in the case of visible damage or where there is prior knowledge of damage that may lead to malfunction.

5.7 MAINTENANCE / REPAIR

Maintenance should be done regularly; at least once in the year. Maintenance and repair of the equipment may be carried out only by Mann Teknik AB or by companies / technicians authorized by Mann Teknik AB (see chapter 6).

5.8 MISCELLANEOUS

The operator is solely responsible for the installation, operation and maintenance of the coupling. Mann Teknik AB accepts no responsibility for damages due to faulty installation, faulty handling, as well as negligent or incorrect maintenance.

6 MAINTENANCE AND REPAIR

6.1 GENERAL INFORMATION

Maintenance tasks may be performed only by trained personnel from an authorised professional workshop. All measures necessary for inspection, maintenance and repair must be carried out in accordance with the national regulations of the country where the system is installed. A separate service instruction is available on request. Notice also our safety instructions (see chapter 2.1).

6.2 MAINTENANCE AND SERVICE INSTRUCTION



Always depressurise the system and rinse off the parts before beginning any maintenance work. Use protective goggles. Do not handle O-ring seals if the material appears charred, gummy or sticky.



Use tweezers; wear gloves and protective goggles in appropriate material, consult the material safety data sheet (MSDS) of your product. Do not touch adjacent parts with unprotected hands. Rinse off the parts once again before starting the “daily inspection”

6.2.1 Daily inspection

1. Inspect the coupling surface for cleanliness and corrosion.
2. Inspect the O-ring in the hose unit connection for serviceability and correct seating in the groove.
3. Inspect the hose unit swivel for free rotation.
4. Inspect the tank- and hose unit for faultlessness and external signs of seizure.

6.2.2 Three-month inspection

1. Exterior cleaning of the coupling halves with a neutral cleanser.
2. Careful "daily inspection" of cleaned units.

6.2.3 Once a year

1. Exchange sealing and washer at least once a year.
2. Refill the hose unit ball bearing grooves with grease
3. Replace worn or damaged components. Repair procedures are straightforward and no special tools are required.

Check the state of the connection surface and verify that it is clean before proceeding with the connection.

Couple the repaired unit to a serviceable hose or tank unit as appropriate and check for correct operation of the valve actuating and bayonet locking mechanism. Couple and uncouple the unit(s) several times.

Use only original Mann Technik spare parts for maintenance.

Spare part kit (S-S4-xx)

O-ring kit (O-S4-yy)

xx and yy means the material key according to the product catalogue. You will find it also as the 6th to 9th sign in the serial number (eg. S414BxxyyB).

6.3 PRESSURE AND TIGHTNESS TEST

After each service a pressure and tightness test of each coupling is mandatory. The following test parameters are in accordance with EN12266 and EN14432:

Shell tightness test (water): 1,5 x Working Pressure (see 1.2) stop time 1 min.

Seat tightness test (air): 6 bar +/- 1bar stop time 15 s.

0,1 x Working Pressure stop time 15 s.

If a pressure test should be achieved for the coupling mounted in an assembly follow the respective test instructions for the equipment but do not exceed 1,5 x Working Pressure of the coupling.

7 APPLICABLE DOCUMENTS

Product standard NATO STANAG 3756

EC Guideline 97/23/EC PED, 94/9/EC ATEX

International Transport of Dangerous Goods ADR, RID, IMDG

Test standards EN12266, EN14432, ISO5208

Thread standards ISO 228, ANSI B1.20.1 - Flange standards EN 1092, ANSI B16.5

For use in Germany:

Facts sheet T 002 (7/2005) BGI 572 of BG Chemie

For use in other countries:

Respective national requirements and guidelines

7.1 DECLARATION OF CONFORMITY



DECLARATION OF CONFORMITY:
Pressure Equipment Directive 97/23/EC

Mann Teknik AB of Mariagatan 29, SE-542 34 Mariestad, Sweden hereby declares that the products listed comply with the essential requirements of the Pressure Equipment Directive 97/23/EC.

Product models listed for category I
assessed according to module A – Internal Production Control

Pressure accessories Mann-Tek DDCouplings (STANAG), DGCouplings

Material PEEK	Material Brass / Gunmetal
Pressure PS=PN	Pressure PS=PN
PN6	PN10
DN40 - DN100	DN65 - DN100
	PN16
	DN50
	PN25
	DN40
Material Aluminium	Material Stainless Steel
PN6	PN6
DN150	DN150
PN10	PN10
DN65 - DN100	DN65 - DN100
PN16	PN16
DN40 - DN50	DN50
	PN25
	DN40

Pressure accessories Mann-Tek DACouplings (ISO45)

Material Aluminium

Pressure PS=PN

PN10

DN65

Products listed for category II
assessed according to module D1 – Production Quality Assurance

Pressure accessories Mann-Tek DDCouplings (STANAG), DGCouplings

Material Brass / Gunmetal	Material Stainless Steel
Pressure PS=PN	Pressure PS=PN
PN16	PN25
DN65 - DN100	DN50 - DN100
	PN16
	DN150

Notified body

Identification number 0038
Lloyds Register Verification Limited
71 Fenchurch Street
EC3M 4BS LONDON
United Kingdom

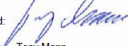
Signed: 

Name: Tony Mann
Title: General Manager
Date: 04 June 2009

97/23/EC PED – Conformity Declaration



DECLARATION OF CONFORMITY: **ATEX EC-Directive 94/9/EC**

Mann Teknik AB of Mariagatan 29, SE-542 34 Mariestad, Sweden, hereby declares that the products listed comply with the essential requirements of the ATEX EC-Directive 94/9/EC.

Product models listed

Pressure accessories Mann-Tek DDCouplings (STANAG), DGCouplings

Material: PEEK	Material: Brass/Gunmetal
Pressure PS=PN	Pressure PS=PN
PN6	PN10
DN25 - DN100	DN65 - DN100
Material: Aluminium	PN16
PN10	DN50
DN65 - DN150	PN25
PN16	DN25 - DN40
	Material: Stainless Steel
	PN25
	DN25 - DN100
	PN16
	DN150

Pressure accessories

Mann-Tek DACouplings (ISO45)

Material: Aluminium

Pressure PS=PN

PN10

DN65

Marking:  II 2G

The manufacturer attested, that the DDCouplings, DACouplings and DGCouplings satisfy the stated requirements and may therefore be used in category 2, group II.

Signed: 

Notified body

Identification number 0038
Lloyds Register Verification Limited
71 Fenchurch Street
EC3M 4BS LONDON
United Kingdom

Name: Tony Mann
Title: General Manager
Date: 26 November 2007

94/9/EC ATEX – Conformity Declaration

© Copyright 2010 Mann Teknik AB. Mann Teknik AB reserves the right to make changes at any time in prices, materials, specifications and models and to discontinue models without notice or obligations.

Mann Teknik AB
Mariagatan 29, S-54234 Mariestad, Sweden
Phone +46 501 393200 ▪ Fax +46 501 393209
www.mann-tek.com ▪ sales@mann-tek.se



Mann Teknik AB is a certified ISO9001-company.