

Gas Handling



MannTek



The MannTek way



Connections, dedicated teams, innovative expertise – all beyond expectations

We strongly believe in connections – in more ways than one. Since 1997 we have been producing innovative and safe coupling products. But that’s not where the story ends. We develop coupling solutions beyond expectations.

None of this would be possible without dedicated teams. Our experienced personnel are the heart of our existence. We deliver engagement and dedication embodied in customised solutions for our customers. In a world where humans create new challenges every day, we provide reliable and innovative solutions to meet our customers’ most pressing needs.

That’s why our organisation is built upon good communication, respect for others, and trust. At MannTek it is essential to connect with each other, with customers and with distributors, based on respect and understanding. Our open working environment and company culture fosters communication and knowledge sharing in a free climate.



Customised solutions

UNLIMITED POSSIBILITIES

Innovative, safe and reliable

SIMPLE EFFICIENCY



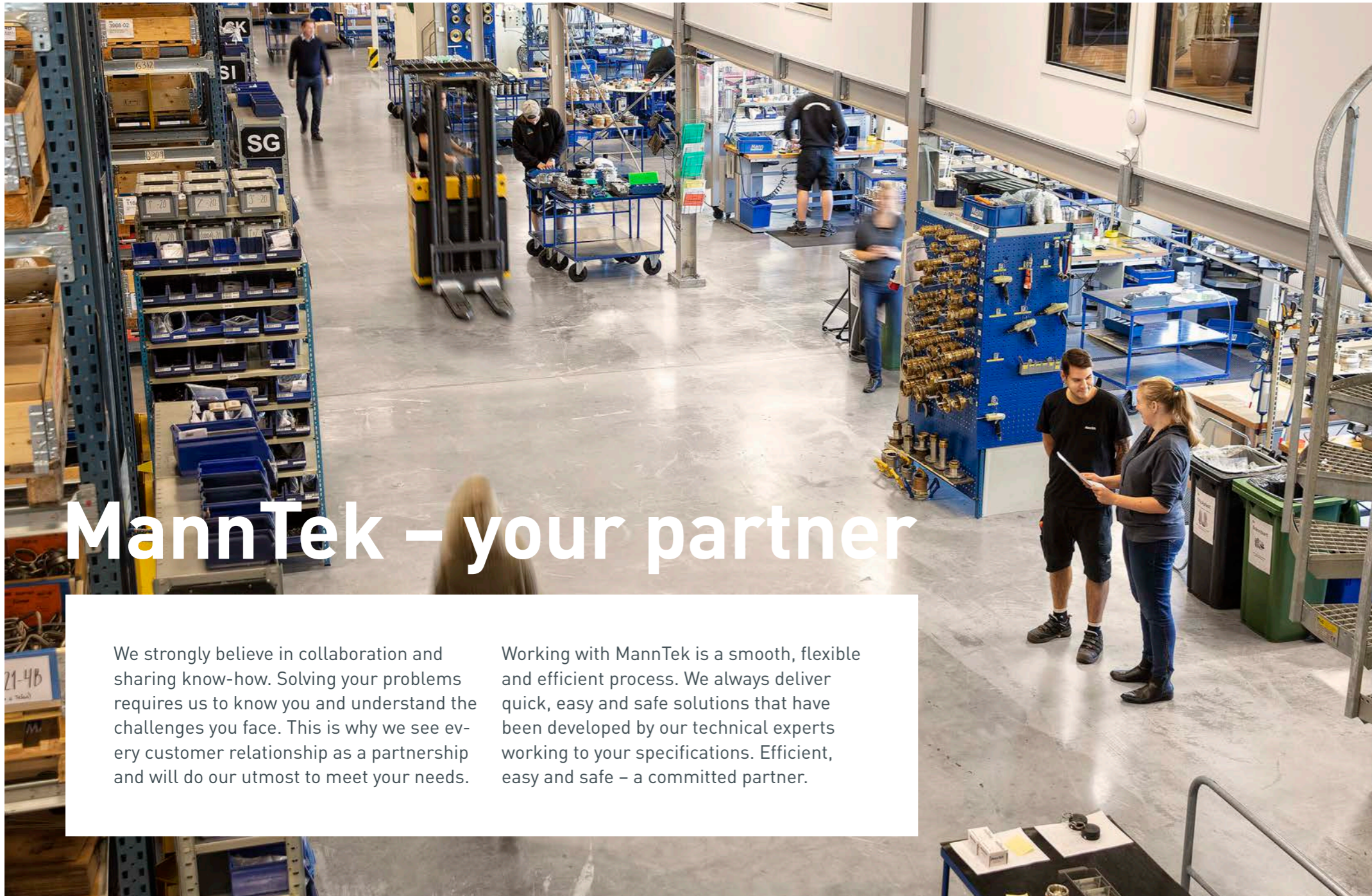

MannTek – your partner

We strongly believe in collaboration and sharing know-how. Solving your problems requires us to know you and understand the challenges you face. This is why we see every customer relationship as a partnership and will do our utmost to meet your needs.

Working with MannTek is a smooth, flexible and efficient process. We always deliver quick, easy and safe solutions that have been developed by our technical experts working to your specifications. Efficient, easy and safe – a committed partner.

A UNIQUE CRAFT

We never compromise with quality. Designing for essential safety requires knowledge, competence and expertise. Our production team has unique skills that take innovation to a new level. This is the foremost reason we can call ourselves market leaders today.



TAILOR-MADE COUPLINGS Working with aggressive fluids, gases and bulk powder requires more than safety. Our couplings guarantee no spill thanks to a tailor-made design. A solution from MannTek is the best way to make sure the work environment remains clean, safe and spill-free.

EASY, READY AND OPTIMISED With more than 20 years of experience of producing couplings for harsh environments, we know the drill. We are continuously improving and extending the performance and design of our products. Working with us is easy as we deliver safe, cost-effective solutions.



BE SAFE – EVERY DAY

Designing pipe works, hoses, valves and tanks for aggressive, explosive or otherwise dangerous media is always challenging. And it's especially challenging to design the parts that human hands touch. Safety, robustness and reliability are what we cope with every day.



We design the widest range of DDC couplings in the world – available in almost any existing metal and many composite materials. Combined with sealing materials with working temperatures from -196°C to $+280^{\circ}\text{C}$, and the largest variation of connections, this makes a unique match to specific requirements. To fulfil special handling procedures our couplings could be equipped to suit almost any requirements.



Service to the food and beverage industry. Our couplings have been used for beer transportation for many years now. Distilleries are now following in their footsteps, as both whisky and other liquor producers appreciate how our dry disconnect couplings improve their working environment. DDCs deliver full spillage control and eliminate unwanted mixing of products.

DGC & DCC

Our Dry Gas Coupling (LPG) and Dry Cryogenic Coupling (LNG) are a further development of our Dry Disconnect Coupling that has been used in decades in the chemical and petrochemical industry. This is the reason why we based our gas handling quick connectors on the same mechanical principle.

There is no other coupling principle that has a longer track record in the industrial field showing a more reliable and robust functionality combined with an absolute

minimum of product loss during connection and disconnection.

The coupling design will eliminate spills to the environment and operators at the same time as it saves money. In many applications the coupling will have a financial pay-off time in a few months. The connection and disconnection is made in seconds which is beneficial to the user and the environment but also makes it possible to disconnect in case of emergency.

DRY GAS COUPLING

Dry Gas Coupling (DGC) is primarily designed for handling LPG or other gases (liquified or in gas phase) at a temperature range down to -50 C. The Dry Gas Coupling is designed to make connections and disconnections at a higher pressure - up to 28 bar (1" to 3").

With our DGC there is no need to empty the hose line or loading arm between fillings, so

the product could remain in liquified phase. This also makes a wet hose concept possible which makes the filling volumes easier to measure. The Dry Gas Couplings are produced in sizes from 1" to 8", housing material is stainless steel and the standard sealings is FKM-low temp which makes them suitable for all different qualities of the LPG and temperatures.

DRY CRYOGENIC COUPLING

Dry Cryogenic Coupling is mostly used for handling LNG but could also be used handling other cryogenic media down to a temperature of -196 C. Also, this type will have the same benefits as all of our Dry Disconnect Couplings with no spill during connections and disconnections and it only takes seconds to connect or break

the hose lines. As both valves close when disconnecting the couplings, there is no necessity to purge or strip the hose line before disconnection. The Dry Cryogenic Couplings are produced in sizes from 1" to 8", the material is stainless steel and the seals are made of PTFE.

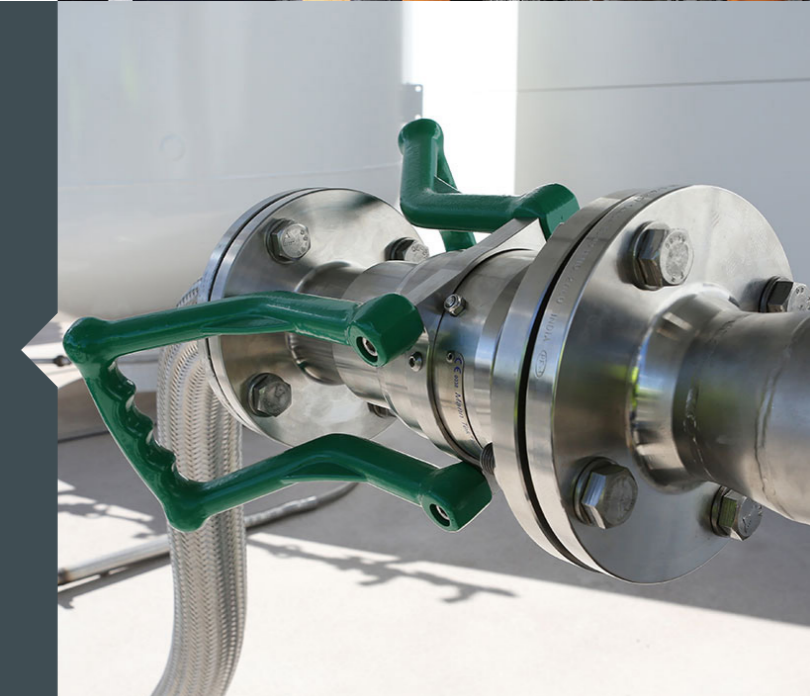

OUR SOLUTION RANGE

DGC – Dry Gas Couplings

DCC – Dry Cryogenic Couplings

SBC – Safety Break-away Couplings for LPG

CBC – Cryogenic Break-away Couplings for LNG

DGC Dry Gas Couplings

MannTek Dry Gas Couplings are designed for spill-free handling. They guarantee economical, safe and environmentally friendly application within the LPG industry. We know the importance of eliminating unwanted leakage, product loss and a safe environment.

+ Key benefits

EASY TO HANDLE

Push and turn - free flow. Turn and pull - closed.

TIME SAVING

No need to drain hoses or pipe systems.

ECONOMICAL

No loss or spillage of liquids on connection or disconnection.

SAFE

The valve cannot be opened until the unit is coupled.

ENVIRONMENTALLY FRIENDLY

Accidental spillage is eliminated.

QUALITY

Designed for a long life cycle and intensive use over many years.

Applications

- Top and bottom loading of tank trucks, bulk tanks, rail tankers, etc.
- Coupling from tank truck to customer storage tank
- Sampling

Large variety of connections (both thread and flange) for mounting directly on hose or tank.

Inner cam curve (protected from external impact).

Dry gas coupling with integrated swivel.

Powerful handle – many alternatives to fit specific use.

Easy service without special tools (market leading solution).

Weight optimised.

Unique low temp FKM sealing technology for all qualities of LPG and temperatures operational.

Robust rubber protecting ring – weather-resistant and electrically non-conductive.

Available in 1" – 8".

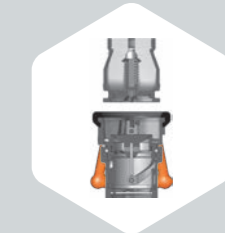

To Connect



Full Flow



To Disconnect

INNOVATIVE ACCESSORIES

Our most innovative accessories are also some of the most popular. Our online configurator will give a complete overview matching your product specifications. Like our couplings, our accessories are always certified by Lloyds, TÜV, Bureau Veritas, Apragaz and TDT, as well as complying with any regionally required approvals.

SAFETY PRESSURE CAP

Contains pressure with built in warning indicators for excessive pressure. Design allows operators to release over pressure in a controlled safe way. Safety Pressure Cap may replace other closure valves (ie ball valves, butterfly valves etc.) and is approved according ADR/RID as third enclosure.

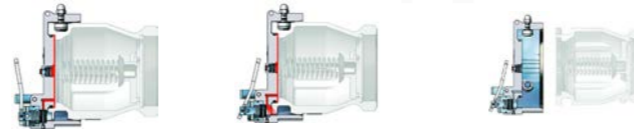

In case of an upstream leakage the cap will indicate it.

Press down the handle and any possible pressure is evacuated through a valve.

The cap can be removed safely.

PRESSURE EQUALIZING VALVE

This system dissipates trapped fluid pressure into the hose coupler without spillage, to allow easy connection. Allows safe opening with balanced pressure.



VALVE CONTROL

This is a feature for detecting leakage in the tank unit. After stop and control for leakage the user must manually unlock the hose unit before disconnection. Both tank unit and hose unit shall be ordered in "Stop Before Disconnect" version.



TANK UNITS WITH ECCENTRIC FLANGES

Tank units / adapters with eccentric flanges are available in sizes 1" to 6". Eliminate risks of liquid remaining in the pipe system.

Equalising the pressure between hose and tank unit, for easy and safe use.



Reverse Search by MannTek Part Number ⓘ

PSXXbar XXXXX

Mtrl.: XXX Year: 20XX/XX

Sample of a MannTek ID Plate. To simplify re-orders type in the existing MannTek part number.

Find all our accessories in one place

Find your customised product easily with our configurator. Your solution is just a few clicks away.

configurator.manntek.se →

Additional Info

Dry Gas Couplings

Copyright Mann Teknik AB / Privacy Terms
Last Update: 10.12.2018

INNOVATIVE ACCESSORIES

Our most innovative accessories are also some of the most popular. Our online configurator will give a complete overview matching your product specifications. Like our couplings, our accessories are always certified by Lloyds, TÜV, Bureau Veritas, Apragaz and TDT, as well as complying with any regionally required approvals.

HOSE UNIT WITH INTEGRATED BREAKAWAY

If there is a risk of excessive force on the hose due to unexpected motion between the loading and unloading units, the DDC can be combined with a safety break away.



ACME AND WHITWORTH THREADS

DGC tank units and hose units are available with ACME and Whitworth threads for direct assembly on existing connections. Open threaded ACME couplings have been used in the LPG industry for a long time resulting in high product losses, environmental effects and health risks.



OVER PRESSURE BLEED VALVE

To protect equipment in special operating conditions where there is the risk of excessive pressure increase through warming in the pipe / hose system. The optional pressure bleeding valve opens at a predetermined pressure limit.

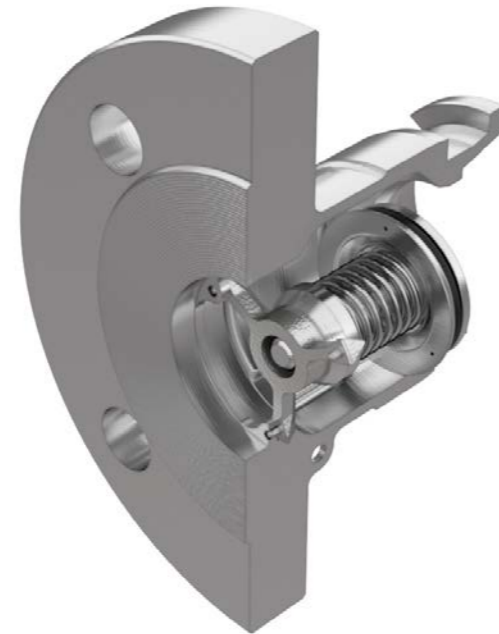

TANK UNIT WITH SHORT PISTON

When coupled, the piston spindle does not protrude. This special type is useful when tank unit is direct mounted to ball valves.

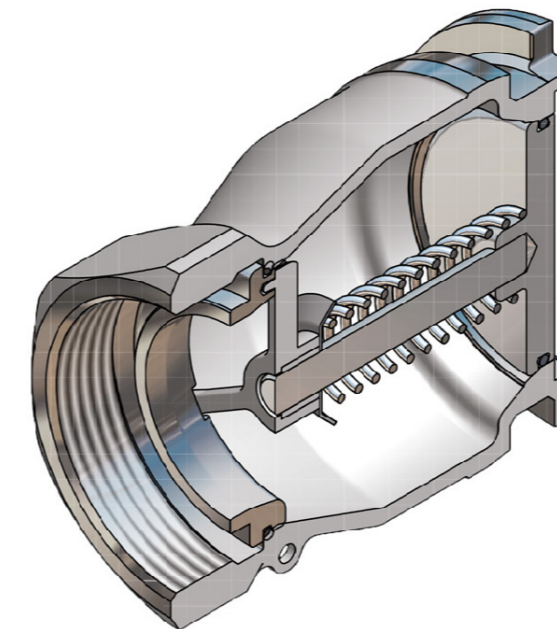

Reverse Search by MannTek Part Number ⓘ

CE MannTek

Type in Part Number

Seal: XXX XXXX

ID:XXXXX

Mtrl.: XXX

Year: 20XX/XX

Sample of a MannTek ID Plate. To simplify re-orders type in the existing MannTek part number.

Find all our accessories in one place

Find your customised product easily with our configurator. Your solution is just a few clicks away.

configurator.manntek.se →



OUR SOLUTION RANGE

DGC – Dry Gas Couplings

DCC – Dry Cryogenic Couplings

SBC – Safety Break-away Couplings for LPG

CBC – Cryogenic Break-away Couplings for LNG

DCC Dry Cryogenic Couplings

DCCs, Dry Cryogenic Couplings, employ the same design principles as our Dry Disconnect Couplings, which have been in use for more than 25 years. Our Dry Cryogenic Couplings have been tested under cryogenic conditions by connecting and disconnecting over 10,000 cycles. With more than 25,000 LNG transfers having been completed using Manntek DCCs, they are considered by operators worldwide to be the safest in the market. These couplings are used for ship to ship transfer, LNG Bunkering, marine applications, filling tank trucks and LNG containers. The proven self-sealing valve design enables quick connection and disconnection while protecting operators, the environment and equipment from dangerous liquids and vapours. The Manntek DCC is designed to be compliant with both ISO 18683 and the new ISO 21593.

+ Key benefits

TIME SAVING Connect or disconnect hoses and pipelines in seconds. No need for retightening during cool down face. Wet disconnect possible. No need for draining during connection.

EASY TO HANDLE Push and turn - free flow. Turn and pull - closed.

SAFE The valve cannot be opened until the unit is coupled and closes automatically when disconnecting.

ENVIRONMENTALLY FRIENDLY Accidental spillage eliminated.

RELIABILITY No loss or spillage of liquids on connection or disconnection.

Applications

- Container discharge
- Fuel bunkering
- Loading/unloading of tank trucks, rail tankers, bunkering and tank vessels
- Vapor recovery lines

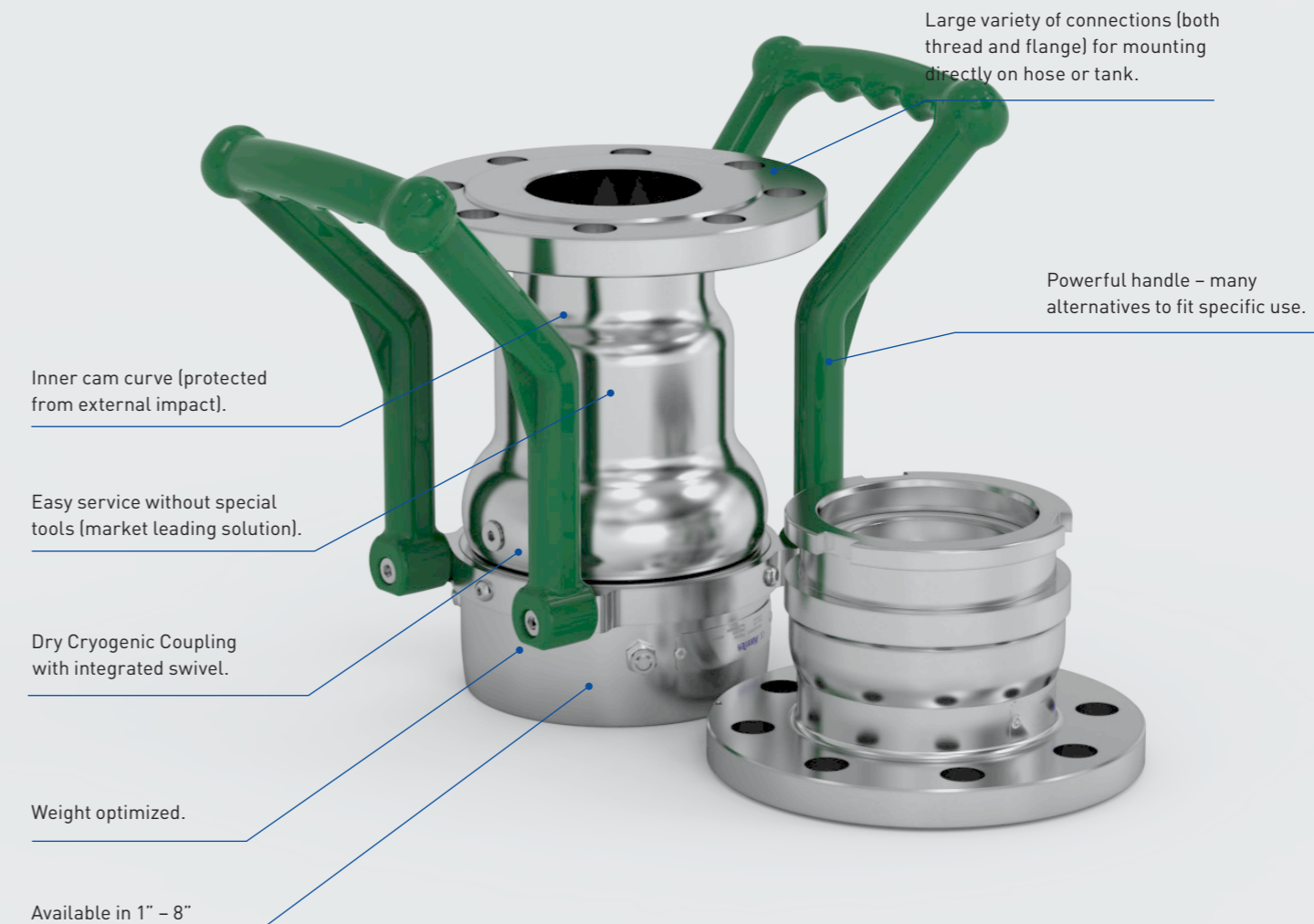

TRY OUR ONLINE CONFIGURATOR

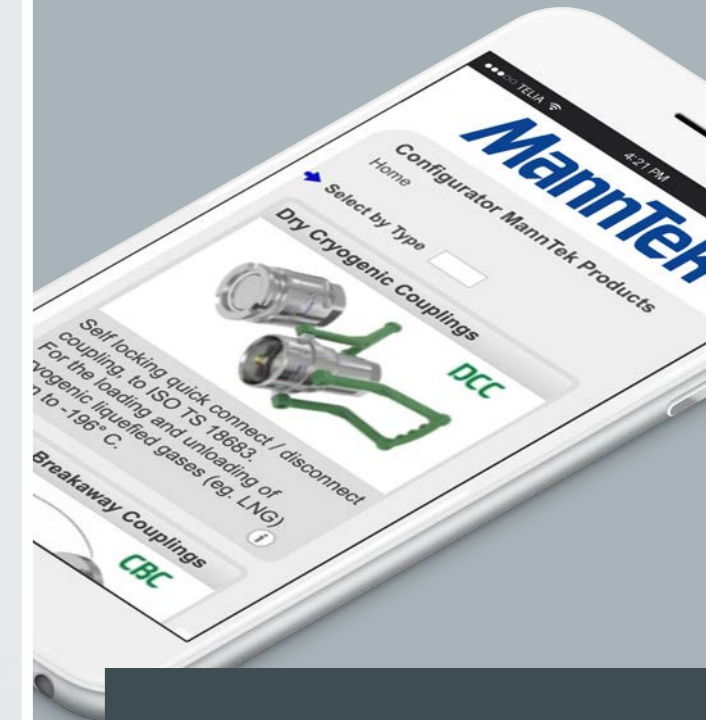

Find your solution

Find your customised product easily with our configurator. Your solution is just a few clicks away.

configurator.manntek.se →

SBC & CBC

Our Safety Breakaway Couplings used for LPG and our Cryogenic Break-away Couplings are based on the same reliable spring-loaded poppet design as our ordinary breakaways. The advantage of the poppet design is that there will be no problem with damaged valves seat or over rotating flip valves that could destroy the coupling if there is a release at a high flow rate or pressure. Furthermore the poppet design has a minimum of moving parts and the valves are oriented in the flow direction which makes

this valve mechanism the most robust and reliable valve concept.

MannTek always strives to make the correct threaded or flanged connection direct in the coupling body to avoid adapters or reducers that increase cost, weight and potential leakage. Our customers are free to combine any threaded or flanged inlet and outlet connection to make a perfect match to the relevant installation.

BREAKING PIN VERSION

The Breaking pin versions are available in two different types: the industrial type that can be released at any angle, mostly used when one side is fixed, and the other side is connected to a hose. The Marine type is mostly used when there is a hose length on both sides of the breakaway, and you want to avoid an unwanted release caused by high bending forces (that is, the forces occurring when hose sections are dangling). A straight pull is the only way to release the Marine type.

The breaking force will be calculated for each demand depending on hose quality, pipe and manifold strength, accepted lateral forces from on a loading arm, working pressure etc.

CABLE RELEASE VERSION

Both SBC and CBC are also available in a cable release version. The valve mechanism is the same as the breaking pin, but the release mechanism is based on two clamps holding the coupling halves together and a ring outside the clamps preventing the clamps from falling off. The wire is connected to the release ring and the other end should be connected to a point that will determine the distance at which the loading equipment should be able to operate. The release force is very low, and the functionality of the release mechanism is more or less

independent from lateral forces or internal pressures. The CBC has a unique ice-breaker function that will prevent ice from disturbing the release mechanism.

Our breakaways are available in sizes from 1" up to 12" and are produced in stainless steel and aluminium as standard, although, based on customer demand, many other materials are possible, such as titanium or hastelloy. The sealing material for LPG is a low temp FKM GFLT. CBCs have seals made of PTFE.



OUR SOLUTION RANGE

DGC – Dry Gas Couplings

DCC – Dry Cryogenic Couplings

SBC – Safety Break-away Couplings for LPG

CBC – Cryogenic Break-away Couplings for LNG

SBC Safety Breakaway Couplings

Prevent pull-away accidents, raising the safety level for transfer systems. Our SBC Couplings are safe, flexible and efficient. There are two types available – breaking bolt or cable release.

+ Key benefits

EASY TO HANDLE Easy for a single person to reset on-site. Lightweight, robust design. Simple mechanism with no loose components that could be lost after release.

SAFE Passive security against situations where a hose or loading arm might be subjected to inadvertent excessive loads.

COST-EFFICIENT Operates independently of shut-off safety system. No external power source required. Very low-loss, positive shut-off of both coupling halves results in minimal product loss.

FLEXIBLE High flow rate/low pressure drop. Available with ANSI/DIN flanges or threaded (BSP or NPT).

Applications

- Ship to rig fluid transfer
- Ship to shore fluid transfer
- Ship to ship fluid transfer
- Bunkering, marine refueling



Easy installation



Calculated breaking point



Valves close on separation for minimal spillage

BREAKING BOLT

Variation of breaking load – will be calculated for each installation.

Available in both an industrial version, with any breaking angle – and a marine version with straight pull only.

Protects line from excess pressure.

Unique low temp FKM sealing technology for all qualities of LPG and temperatures operational.

Choose inlet and outlet connections individually – any combination of connection available.

After activation, the unit can be reset in minutes without special tools.

Reliable poppet valve design.

Easy to service – no special tools needed.

No nipples or reducers necessary – produced with a wide range of flanges and threads.

Available with integrated hose shank.

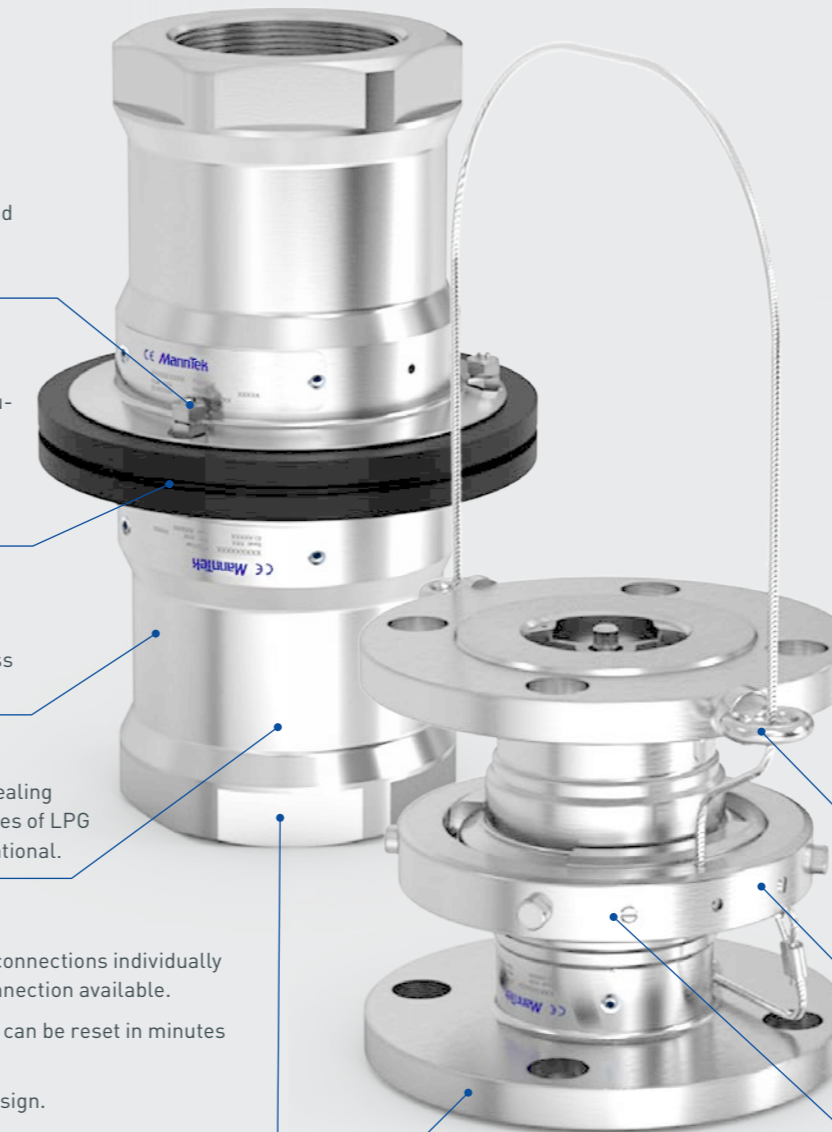

In Service

The coupling consists of two halves, each with a valve.

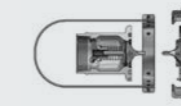

Released

After an emergency disconnection the coupling separates and both valves close immediately.

CABLE RELEASE

Breaking force independent from line pressure and lateral force.

Withstands extreme side load.

Low breaking force.

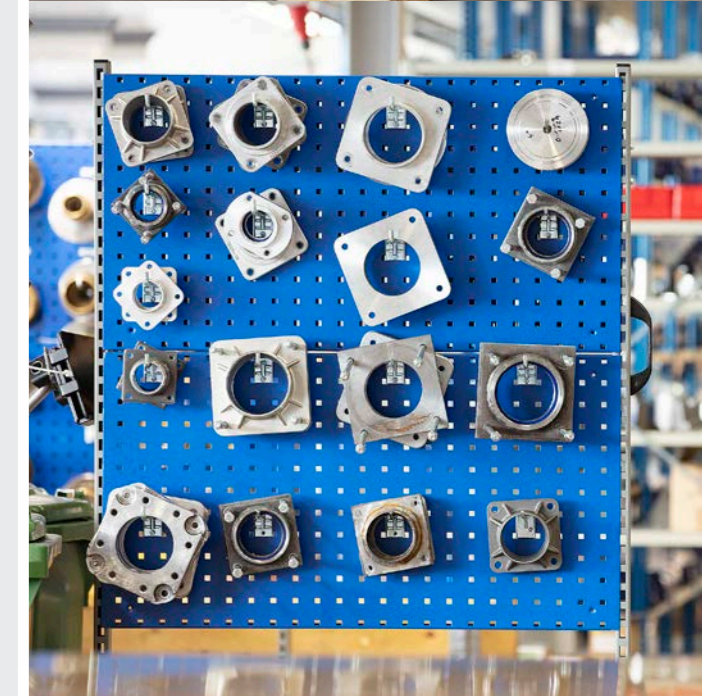
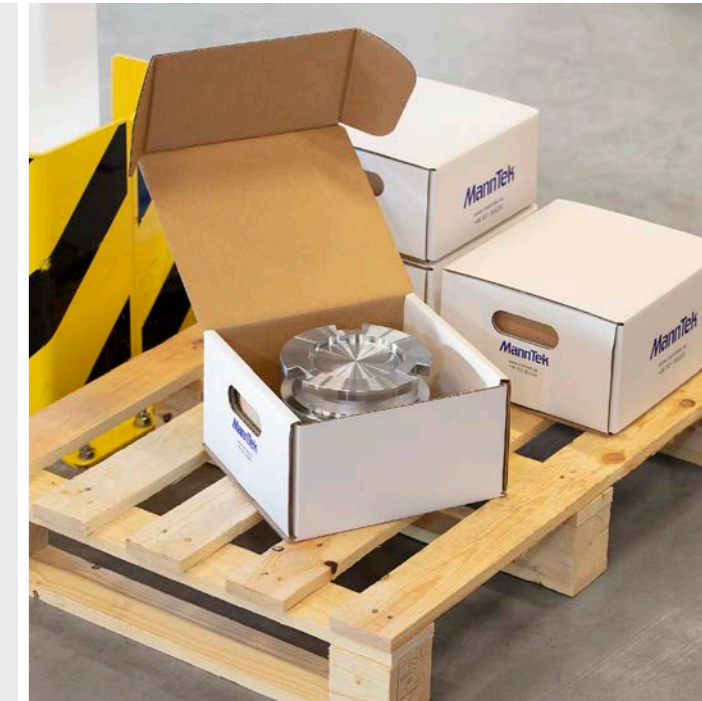

OUR SOLUTION RANGE

DGC – Dry Gas Couplings

DCC – Dry Cryogenic Couplings

SBC – Safety Break-away Couplings for LPG

CBC – Cryogenic Break-away Couplings for LNG

CBC Cryogenic Break-away Couplings

The **CBC (Cryogenic Breakaway Couplings)** product line is available in three different designs suited to a wide array of applications. All three configurations use the same reliable and well-proven closure mechanism with an optimised poppet, designed to close and stop the flow while containing the product in the hose and pipe.

+ Key benefits

PASSIVE SECURITY against situations where a hose or loading arm could be subjected to accidental high loads.

A SIMPLE MECHANISM and no loose components that could be lost after release.

OPERATES INDEPENDENTLY of shut off safety system and does not require an external power source.

EASY TO RESET by a single person on-site.

HIGH FLOWRATE / LOW PRESSURE DROP

NO PRODUCT LOSS, positive shut-off of both coupling halves results in minimum wastage.

LIGHTWEIGHT AND ROBUST DESIGN. Available with ANSI/EN flanges or threaded (female NPT).

Applications

- Container discharge
- Fuel bunkering
- Loading/unloading of tank trucks, rail tankers, bunkering and tank vessels
- Vapour recovery lines

CABLE RELEASE

Breaking force more independent from pressure.

Withstands extreme side load.

Unique ice breaking function.

Low breaking force.

Choose inlet and outlet connections individually – any combination of connection available.

After activation the unit can be reset in minutes without special tools.

Reliable poppet valve design.

No nipples or reducers necessary – produced with a wide range of flanges and threads.

Easy to service – no special tools needed.

Available with integrated hose shank.

BREAKING BOLT

Variation of break load – will be calculated for each installation.

Protect line from over pressure.

Available in both industrial version with any breaking angle – and marine type with straight pull only.



SHIPPING WORLDWIDE

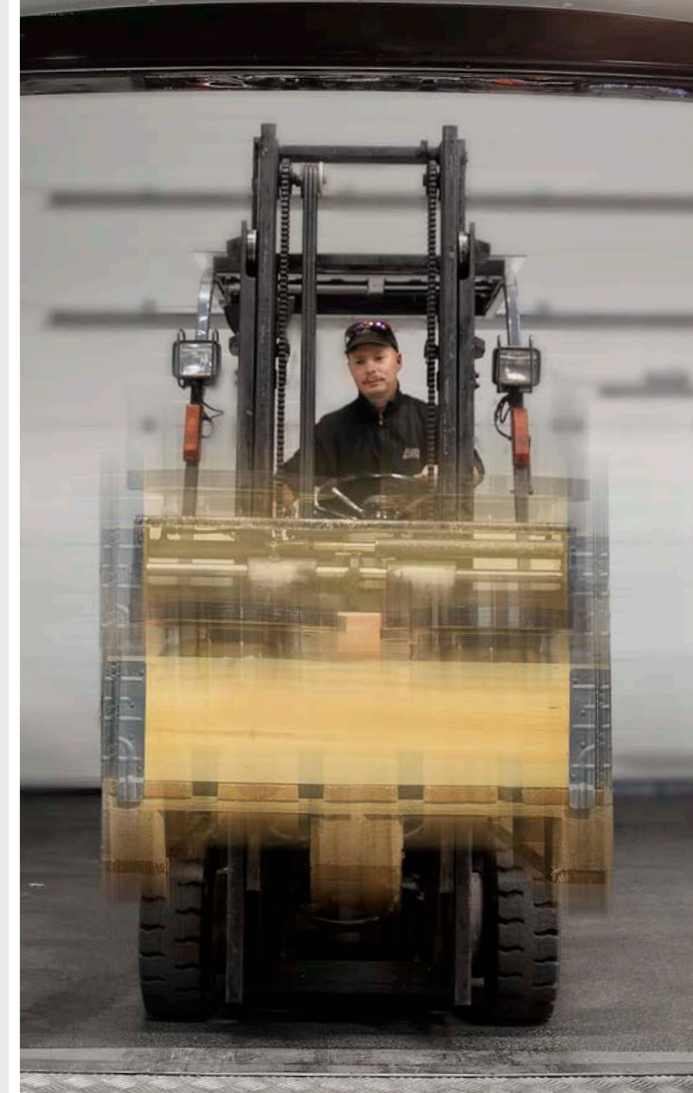

INNOVATIVE ACCESSORIES

Our most innovative accessories are also some of the most popular. Our online configurator will give a complete overview matching your product specifications. Like our couplings, our accessories are always certified by Lloyds, TÜV, Bureau Veritas, Apragaz and TDT, as well as complying with any regionally required approvals.

DUST CAP & DUST PLUG

Dust plug to protect the couplings against the ingress of dirt and water.



HEATED PARKING DEVICE

Heated parking device is used to easily defrost and dry the hose unit after LNG transfer operation. The heated parking device ensures that the hose unit will be ready for transfer operations again within minutes.



PARKING DEVICE

For safe and dedicated storage of hose unit.



PRESSURIZED DUST CAP

Dust and deicing cap for tank unit that ensure clean and dry sealing interface within minutes.



Reverse Search by MannTek Part Number ⓘ

CE MannTek

Type in Part Number

Seal: XXXX Mtrl.: XXX XXXXX

ID:XXXXX Year: 20XX/XX

Sample of a MannTek ID Plate.

To simplify re-orders type in the existing MannTek part number.

Find all our accessories in one place

Find your customised product easily with our configurator. Your solution is just a few clicks away.

configurator.manntek.se →

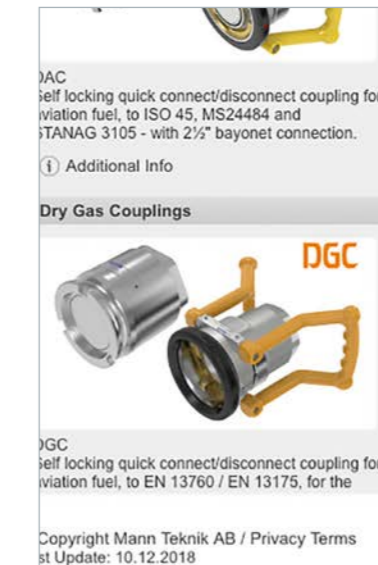



TRY OUR ONLINE CONFIGURATOR

Find your solution

Search by part number



configurator.manntek.se →



MannTek

Phone +46 501 39 32 00
Fax +46 501 39 32 09
Email sales@manntek.se
Website www.manntek.se
Address Mann Teknik AB
 Strandvägen 16
 S-542 39 Mariestad
 Sweden

Sales office
 Argentina China
 Germany Great Britain
 Netherlands Sweden
 United Arab Emirates Spain
 India

COMPANY APPROVALS

