

## PERC Service instruction 8"

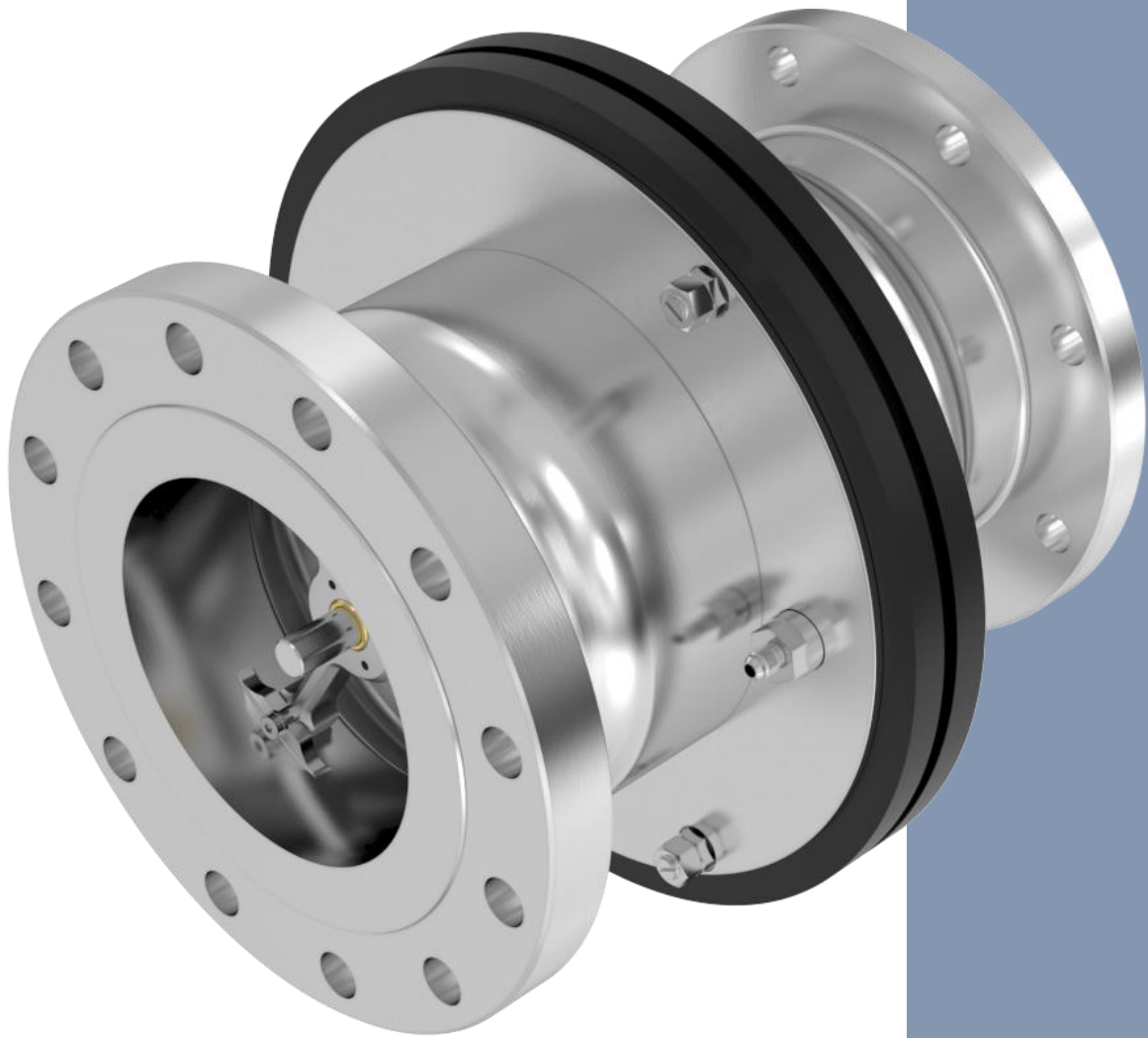

## Quality, Health, Safety and Environment Policy

Our objectives are simple – no accidents, no occupational illness or work related accidents, no negative environmental impact and optimizing and continuously improving customer satisfaction wherever we operate.

Mariestad, December 14 2016



Markus Bäckström

What does this mean?

In our daily work to develop, sell, deliver and maintain our products this means to act as soon as we recognize a risk for:

- Delivery of products with insufficient technical quality
- Giving incorrect information
- Not complying with laws and regulations concerning our operation
- Causing negative environmental impact
- Causing occupational illness or accidents
- Not be able to keep promises on delivery terms (product and information)

To act, here means to point out the risk and to make sure we take a balanced decision to prevent what is undesired.

(This policy includes all that is traditionally covered in separate policies for quality, health, safety and environment)

## PERC 8" MATERIAL: SS

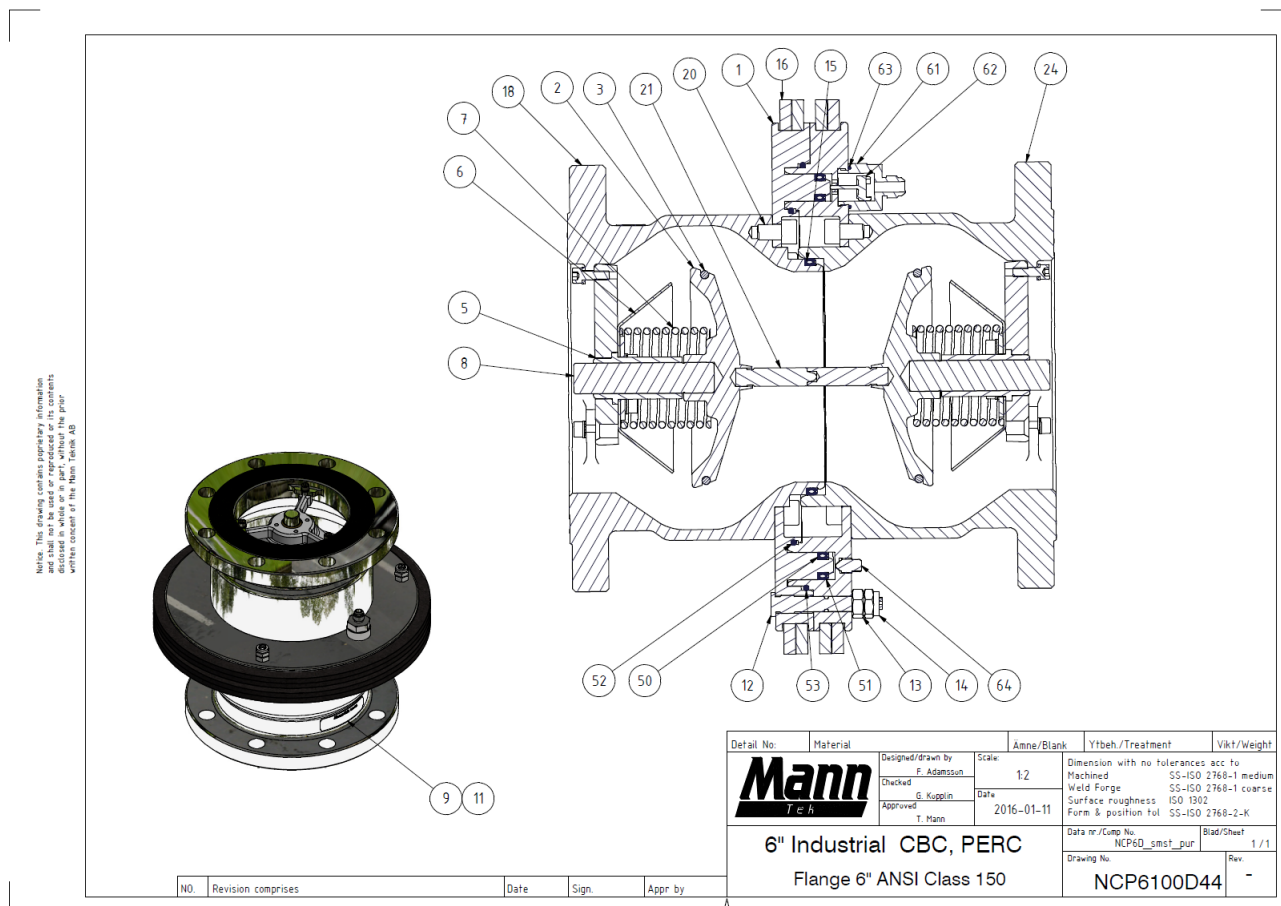

Parts needed for service:  
Type of connection:

Spare part kit and Seal kit (see p. 4)  
Threaded and Flanged couplings have the same service instruction.

Perform a service:

If leaking  
According to application service plan

Tools needed for service:

TOOL 001  
TOOL 030  
Screwdriver  
21mm Wrench



# MannTek

## MAINTENANCE AND SERVICE INSTRUCTION



Always depressurise the system and rinse off the parts before beginning any maintenance work. Use protective goggles.



Use tweezers and wear gloves which are sufficient for cryogenic applications. Do not touch adjacent parts with unprotected hands. Rinse off the parts once again before starting the “daily inspection”

## DAILY INSPECTION

All couplings should be briefly inspected at the start of each day’s operation. Check for dirt, seal damage and any obvious physical damage (such as impacts, etc.).

## REGULAR SERVICE

Regular service interval is very much depending on local regulations and application conditions. If nothing else is specified and it is a new application with unknown parameters, we recommend to make a first service after one year and decide then depending on the inspection result about further intervals.

The service procedure shall be as follows:

1. Exchange sealing at least once a year.
2. Replace worn or damaged components.

## REASSEMBLING AFTER RELEASE

Follow steps 1-2 & 11-17 to reassemble the coupling after release.

## USE ONLY ORIGINAL MANNTEK SPARE PARTS FOR MAINTENANCE.

## SPARE PART KIT

Example for a 8” coupling (NCP8...)

Seal kit (O-NCP8-06)

Bolt kit (S-NCP8-44-xx)

xx means the break force on the bolt. The break force can be found on the ID plate and on each bolt.



### **PLEASE NOTE!**

Make sure that you are using no grease for cryogenic applications.

PICTURES MAY DIFFER FROM ORIGINAL PRODUCT

## 1. AFTER RELEASE

When the coupling should go into service there is a danger that the fluid will spurt out. Special protective measures such as personal protective equipment must therefore be adopted. Always ensure the system is cleaned in a proper manner. After cleaning, remove any residue from the cleaning agent.



- a Wear suitable personal protective equipment.
- b Make sure that the coupling is depressurized and empty.
- c Clean coupling before disassembly (use cleaning agent suitable for the pumped fluid).



## 2. VISUAL INSPECTION

Screw out the destroyed parts of the breaking bolts.

Check for dirt, seal damage and any obvious physical damage (such as impacts, etc.).



## 3. DISASSEMBLE

Unscrew the three screws that lock the spindle steering.



There is a distance pin in the piston protruding from the housing.

For disassembling a support plate with a hole in the middle, where the distance pin will get free, will avoid any damage of the inner parts



## 4. DISASSEMBLE

Press down the spindle steering and turn it free. Release it carefully



Piston guide is spring loaded. Risk of injury.

Using our special tool makes work easier and therefore increases safety.

Repeat the same procedure as described in step 3+4 with the second half.

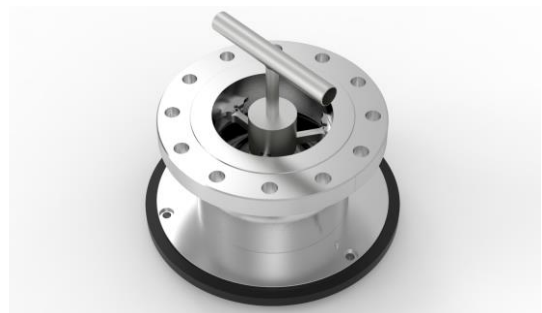

## 5. DETAIL PARTS AFTER DISASSEMBLING

Take out all the parts from the body

- Pos.2 – Piston
- Pos.7 – Spring
- Pos.5 – Spring cap
- Pos.4 – Spindle steering
- Pos.18 – Body

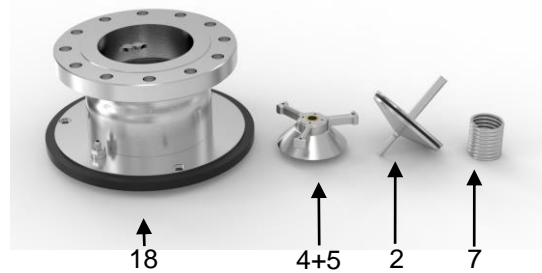

## 6. PISTON O-RING

Replace the O-ring (pos.3) on the piston with a new O-ring.



Be careful when removing the O-ring. Do not scratch the sealing surface.



Make sure that the seal doesn't get scratched when mounting.

For mounting the new O-ring use MannTek spare parts only.



## 7. PERC

Test if the Perc valve is rotating without problems

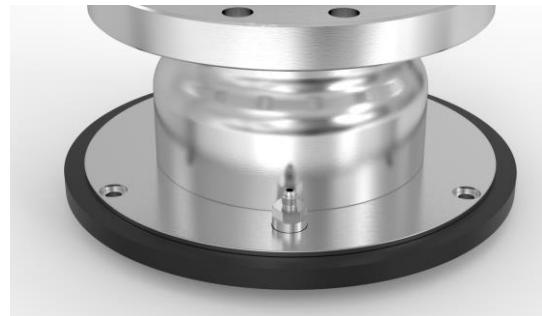

## 8. MOUNTING PISTON

The piston is bigger in diameter than the three brackets for the piston guide.

Introduce the piston as shown. Put it into a relaxing position in the valve seat. Take care; the piston is sticking out on the other side.

For assembling a support plate with a hole in the middle will be helpful.

## 9. Reassemble coupling halves

Fit the spring with spring cap and spindle steering with guidance bushing. Press down the spindle steering and turn, to fix it in its position.

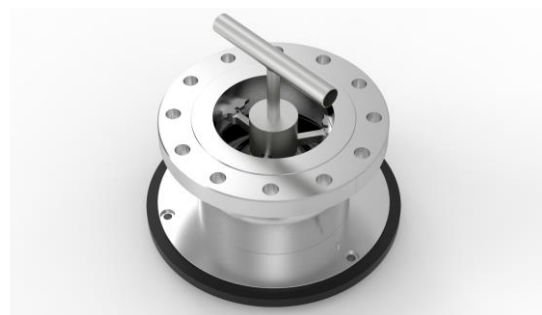

## 10. LOCKING THE SPINDLE STEERING

Fit the screws into the given holes in the body and fix the spindle steering by mounting the three locking screws. Use Loctite® 243 for locking the screws.

Repeat the same procedure with the second half.



## 11. OUTER BODY SEALING RING

Replace the sealing rings (pos.15, pos.50, pos.51, pos.52, pos.53) on the body with a new one.



Be careful when removing the lip-seal. Do not scratch the sealing surface.



Make sure that the seal doesn't get scratched when mounting. The open profile should be in the direction which is shown in the picture.



## 12. BREAKING BOLTS

Replace the bolts only by original spare parts from MannTek with the same breaking force.

Total break force for the bolts can be found on the head of each bolt. (13 kN in the pictures)

Left: destroyed bolt after release

Right: new breaking bolt

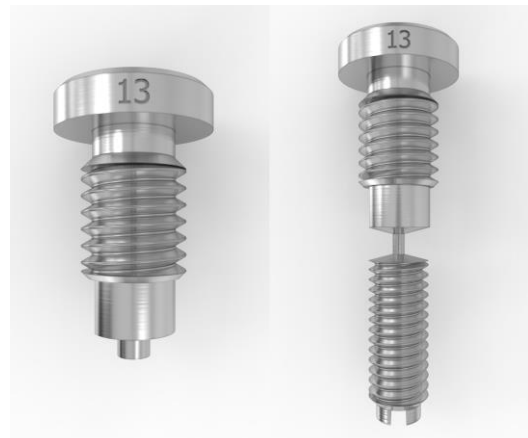

## 13. BREAKING BOLTS

Screw in the bolts into the intended position. If necessary, tighten the bolt with a wrench.



Do not use a screwdriver over the weak section



## 14. REASSEMBLE COUPLING

Set both halves onto each other and press them carefully together. The breaking pins should align to the bore holes in the second half.



It is important that the bodies align to each other when pressing the halves together. Do it carefully, not to destroy the lip-seal.



Using a press and a fixture makes work easier.

## 15. FIX BREAKING BOLTS

Screw on the nuts by hand until stop when halves are pressed together.



Do not use force for tightening! Risk of destroying bolts.

## 16. FIX BREAKING BOLTS

Fasten it a little bit with a wrench, max 45 degrees.

Tool: Standard wrench 17mm



It is important that all 3 bolts are mounted in the same way. Risk that one bolt will be destroyed before the others.

## 17. FIX BREAKING BOLTS

Screw on the second nut and lock the first one. Hold the first one with a wrench to avoid forces on the breaking bolt. After the coupling is completely reassembled provide a pressure test according to test procedure on page 9.

Loctite® is registered trademark of Henkel.





## TEST PROCEDURE

After each service a tightness test of each coupling is mandatory.

The following test parameters are in accordance with EN12266, EN14432 and ISO5208:

Shell tightness test (air/N<sub>2</sub>):                      6 bar +/- 1bar    stop time 60 s.

Instead of dry air / N<sub>2</sub> we recommend making the tightness test with liquid nitrogen or with LNG.

If a pressure test should be achieved for the coupling mounted in an assembly, follow the respective test instructions for the equipment but do not exceed our recommended maximum test pressure of the coupling which you will find in the following table. If testing with higher pressure is necessary, please ask our sales department for a special test bolt kit.

It is not recommended to use liquids for the tests which will freeze under operation with LNG. If so, it must be guaranteed that the coupling is completely free of liquid before it will be used in operation.

Maximum Test Pressure depending on size and breaking force:

DN 25		DN 50		DN 65		DN 80		DN 100		DN 125		DN 150	
kN	bar	kN	bar	kN	bar	kN	bar	kN	bar	kN	bar	kN	bar
		4	10	7	10	11	10	18	10	28	10	40	10
		6	16	10	16	15	16	24	16	37	16	54	16
		7	20	12	20	18	20	28	20	45	20	65	20
		9	25	15	20	23	25	36	25	56	25	81	25
												92	25
3	16	12	50	20	30	30	32	48	35	75	40	108	40
3,2	16	13	37,5	22	37,5	33	37,5	52	37,5	81	37,5	117	37,5

Approved couplings get stamped on the piston.

Number tested: 100%

## STORAGE

Store coupling in a dry, dust free, dark place, in ambient temperature.