

DCC Service instruction 4" hose unit

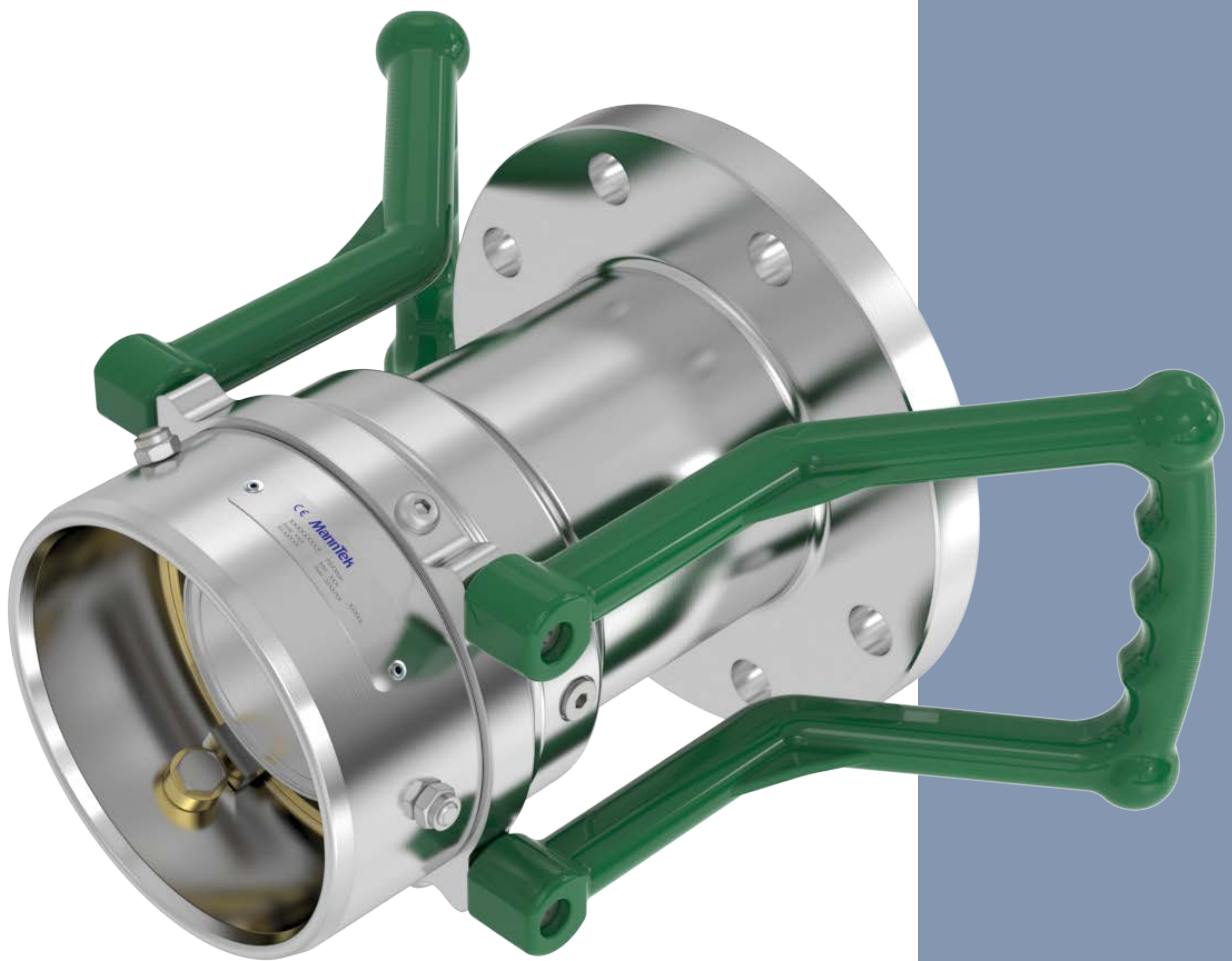

Quality, Health, Safety and Environment Policy

Our objectives are simple – no accidents, no occupational illness or work related accidents, no negative environmental impact and optimizing and continuously improving customer satisfaction wherever we operate.

Mariestad, December 14 2016



Markus Bäckström

What does this mean?

In our daily work to develop, sell, deliver and maintain our products this means to act as soon as we recognize a risk for:

- Delivery of products with insufficient technical quality
- Giving incorrect information
- Not complying with laws and regulations concerning our operation
- Causing negative environmental impact
- Causing occupational illness or accidents
- Not be able to keep promises on delivery terms (product and information)

To act, here means to point out the risk and to make sure we take a balanced decision to prevent what is undesired.

(This policy includes all that is traditionally covered in separate policies for quality, health, safety and environment)

HOSE UNIT 4" MATERIAL: SS

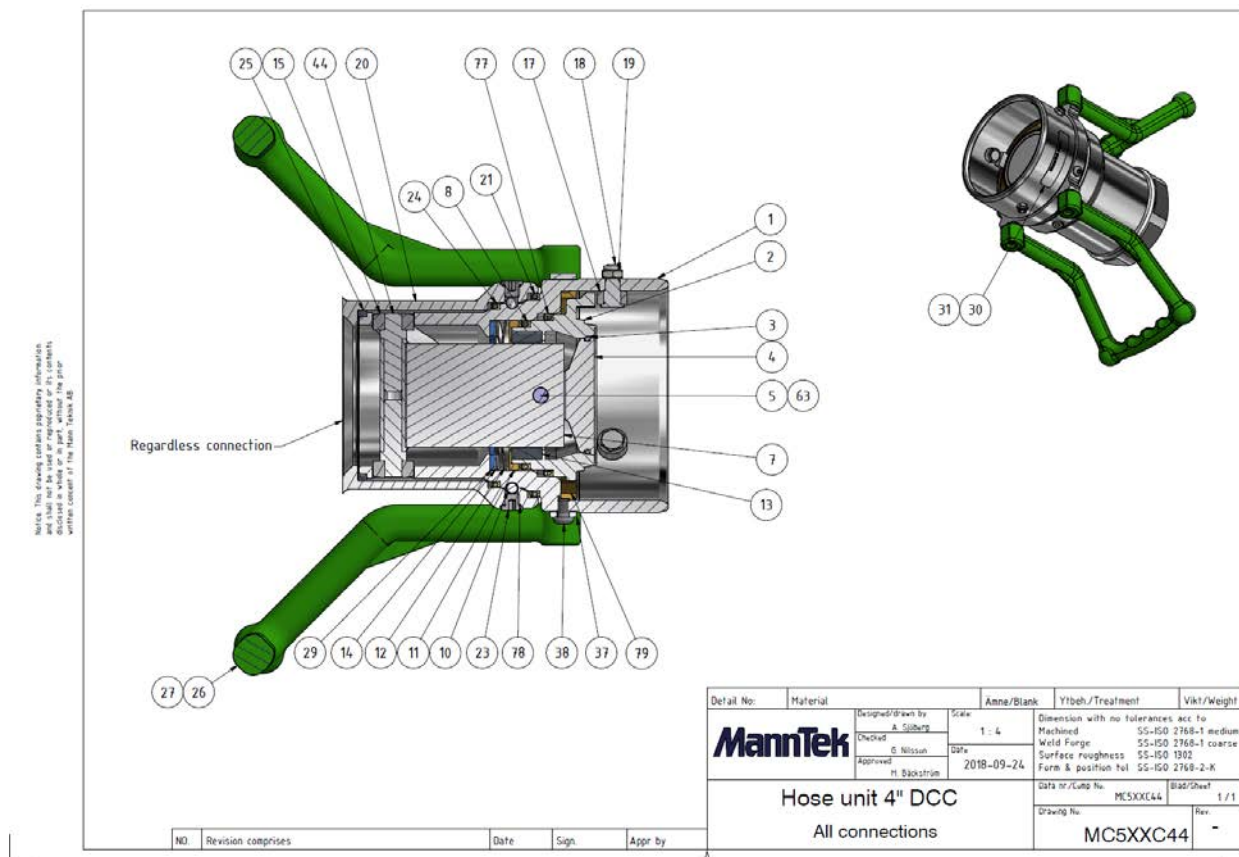

PARTS NEEDED FOR SERVICE: Spare part kit and O-ring kit (see page 4)
TYPE OF CONNECTION: Threaded and Flanged couplings have the same service instruction.

PERFORM A SERVICE: If leaking
 According to application service plan



PLEASE NOTE!

Make sure that you are using no grease for cryogenic applications.

MAINTENANCE AND SERVICE INSTRUCTION



Always depressurise the system and rinse off the parts before beginning any maintenance work. Use protective goggles.



Use tweezers and wear gloves which are sufficient for cryogenic applications. Do not touch adjacent parts with unprotected hands. Rinse off the parts once again before starting the “daily inspection”

DAILY INSPECTION

1. Inspect the coupling surface for cleanliness and corrosion.
2. Inspect the hose unit swivel for free rotation.
3. Inspect the tank- and hose unit for faultlessness and external signs of seizure.

REGULAR SERVICE

Regular service interval is very much depending on local regulations and application conditions. If nothing else is specified and it is a new application with unknown parameters we recommend to make a first service after 6 months and decide then depending on the inspection result about further intervals.

The service procedure shall be as follows:

1. Exchange sealing and washer.
2. Check the hose unit ball bearing for faultlessness.
3. Replace worn or damaged components.

Check the state of the connection surface and verify that it is clean before proceeding with the connection.

Couple the repaired unit to a serviceable hose or tank unit as appropriate and check for correct operation of the valve actuating and bayonet locking mechanism. Couple and uncouple the unit(s) several times.

USE ONLY ORIGINAL MANNTEK SPARE PARTS FOR MAINTENANCE.

NOTE! Both kits are needed when doing service.

Spare part kit (S-MC5C-xx)

Seal kit (O-MC5C-06V)

xx means the material key according to the product catalogue. You will find it also as the 7th and 8th sign in the serial number (e.g. MC563Cxx).



Unscrew and remove the lock screw (pos 23) and o-ring (pos 78) from the swivel sleeve.

Tool: Hexagon wrench No. 5



Put a small container underneath the coupling and start twisting the svivel sleeve, so the balls drop out, into the container. Placing a tank unit in the hose unit will make it easier to twist. Save the 48 balls for reassembling later.



Remove the swivel sleeve by pulling out the hose unit body with the inner package. If the swivel sleeve cant be removed, there might be some balls left inside. Try turning back and forth again to get out the remaining balls.

Remove the shaft and rollers (pos 15 & 44) for piston guide, by applying slight pressure to the driving plate package so that it moves down, until the driving plate package is released from the rollers.



The ring surface on the top of the driving plate is a sealing surface. Press down the piston only, the driving plate will follow.

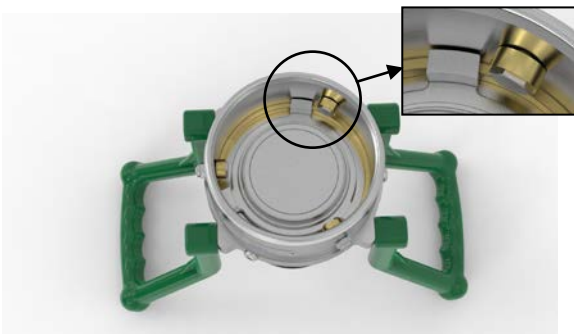

Turn the driving plate to the position where the driving plate heels are coming free from the rollers. It could be necessary to release the package from the press force.

Remove the driving plate package from the hose unit body.

(There are different ways to remove the driving plate package. If yours is not possible to remove, ask your sales representative for an updated instruction)

Tool: Pliers



Remove the inner package from the hose unit body.

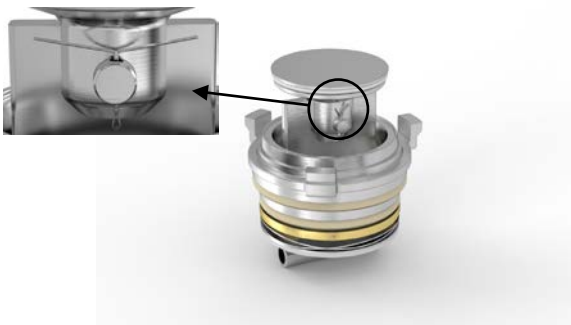

Dismounting the inner package by removing the pin and splint (pos 5 & 63) from the piston. Remove all parts from the inner package in order to change the seal (pos 8) on the driving plate and the seal (pos 3) on the piston.



Change the seal (pos 8) on the driving plate back side.



Make sure that the seal doesn't get scratched when mounting. The open profile should be in the direction which is shown in the picture.



Change the bushings for piston guide (pos 13) and the support ring (pos 11) to new ones.

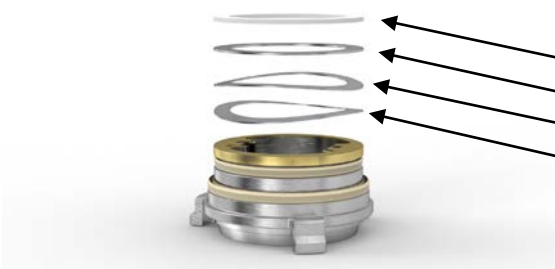

Place the flat seal (pos 29) and wave washer (pos 12) as shown in the picture.

- Flat seal
- Washer
- Wave washer
- Wave washer

Change the O-ring (pos 3) on the piston. Make sure that the O-ring doesn't get scratches when mounting.



Reassemble the inner package.



Reassemble the piston on the piston guide, make sure that the splint (pos 63) is correct mounted.



If necessary change the three shafts (pos.18), locking nuts (pos.19) and rollers (pos.17) to new ones.

Tool: Standard wrench 13 mm



Check the rollers for easy rotation.





Before the coupling body is placed back on the driving plate package, make sure that the part where the upper cam curve ends, shall be placed exactly over one roll, and the heel on the driving plate package should be placed under the hole for the shaft.

Place the coupling body over the driving plate package. Grab the piston guide and turn the unit upside down.

(There are different ways to mount the driving plate package. If yours is not possible like this, ask your sales representative for an updated instruction)

Assemble the shaft and two rollers for piston guide by applying pressure to the driving plate packet.

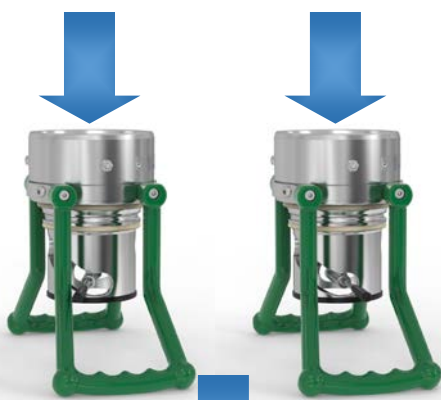

Do not apply too much pressure onto the inner package, only that the shaft and the rollers are easy to fit.

Turn the piston guide to the right position.



When mounting back the rollers on the shaft make sure that the flat side of the rollers face into the coupling.

Change the seals (pos 21 & 24) in the swivel sleeve.



Make sure that the seal doesn't get scratched when mounting. The open profile should be in the direction which is shown in the picture.



Mount the swivel sleeve over the coupling body by using either a press or vise to push them together.

MannTek



Drop the 48 balls into the swivel joint, turn the swivel sleeve after each ball.



Use Loctite® 243 and screw the lock screw (pos 23) and o-ring (pos 78) into the swivel ring without any force! Risk to deform the ball bearing!



Finally, make a visual inspection that everything is in its place. Do also a test connection / disconnection with a tank unit that doesn't have any fluid inside. If the coupling works alright you are ready to do a tightness test before mounting the hose unit on your hose again.

Loctite® is registered trademark of Henkel.

TEST PROCEDURE

After each service a tightness test of each coupling is mandatory.
The following test parameters are in accordance with EN12266 and EN14432:

Test procedure	Test pressure	Acceptance criteria
Tightness test (liquid nitrogen)	6 bar +/- 1 bar	No visually detectable leakage for the duration of the test

Table 1 – Test pressure

Size	Cooling down	Keeping time
DN 25	5 min	30 s
DN 50	10 min	45 s
DN 65	12 min	60 s
DN 80	15 min	60 s
DN 100	18 min	90 s
DN 150	20 min	120 s

Table 2 – Minimum test duration

TEST PROCEDURE:

- Connect the hose unit to the tank unit
- At the beginning the couplings shall be cooled down by opening the tank with liquid nitrogen for the cooling down time specified in Table 2.
- Maintain the test pressure for the keeping time specified in Table 2.
- Determine the leakage rate.
- Disconnect the hose unit and the tank unit.
- Maintain a test pressure of 5 bar in the tested unit(s) for the keeping time specified in Table 2
- Determine the leakage rate while depressurizing the units.

STORAGE

Store coupling in a dry, dust free, dark place, in ambient temperature.